

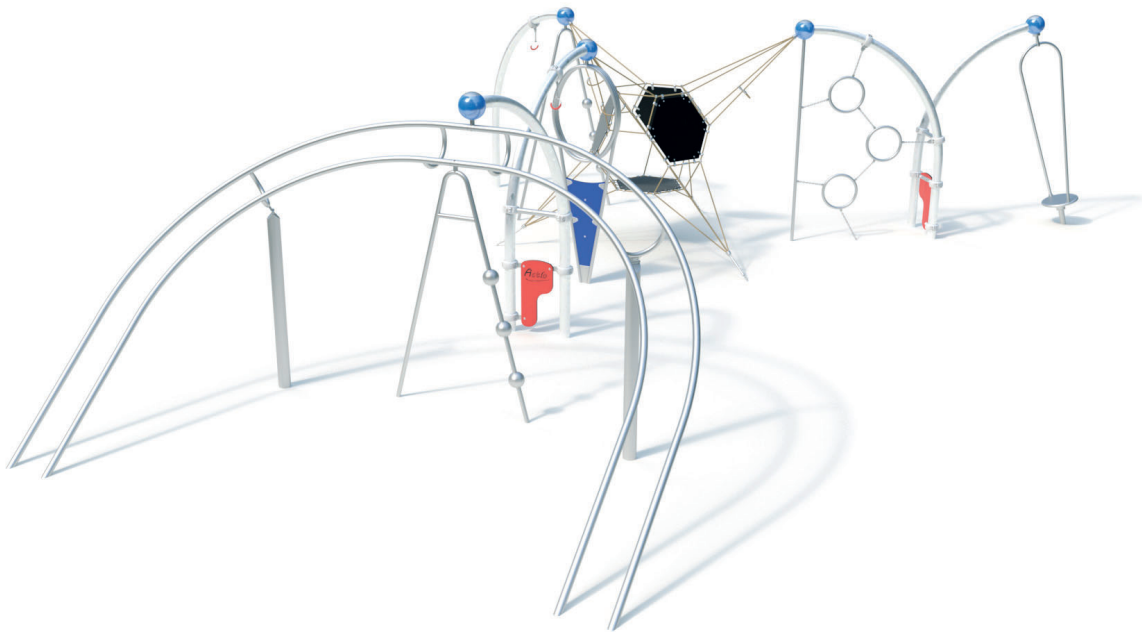

INSTALLATION

0-27501-000

Actio 501



Outils nécessaires

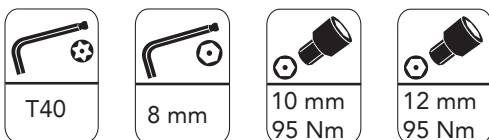

Kaiser & Kühne

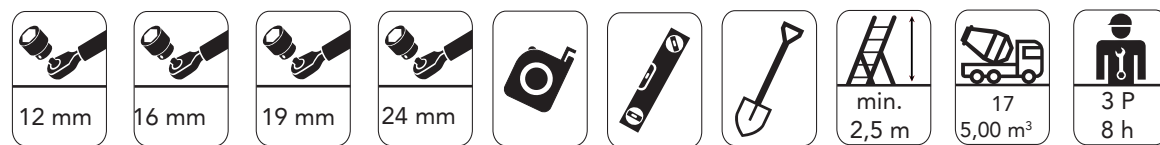

non fourni

Instructions de montage

DE

1. Gerätestandort unter Berücksichtigung des Platzbedarfs (Aufprallfläche) festlegen.
2. Bodenaushub für Fundamente nach Zeichnung vornehmen. Bitte beachten Sie: Für eine stand-sichere Montage werden mittelschwer lösbare Bodenarten vorausgesetzt.
3. Ca. 10 cm dicke Grobkieschicht als Drainschicht zwischen Unterseite der Standpfosten und der Fundamentsohle einbringen.
4. Rohrbogenstütze in das jeweilige Fundamentloch stellen.
5. Bauteile lose verschrauben.
6. Zum Einbauen der vormontierten Bauteile bzw. Einzelteile müssen die Schrauben mit der gelieferten Montagepaste leicht gefettet werden. Erst nach dem Ausrichten alle Schrauben fest anziehen.
7. Fundamente mit Stampfbeton C20/25 füllen, und mit einem Bodenmaterial abdecken, dessen kritische Fallhöhe größer gleich der maximalen freien Fallhöhe ist (s. EN 1176-1).
8. Freigabe zum Spielen erst nach Abbinden der Betonfundamente.
9. Alle Schraubverbindungen gemäß Wartungsanleitung nach 4-5 Wochen überprüfen und ggf. fest nachziehen. Alle mit dem Gerät gelieferten Spezialwerkzeuge (z.B. Innensechskant-Schlüssel für gesicherte Schrauben etc.) sowie alle gerätespezifischen Unterlagen, die für das Sicherheitsmanagement nach EN 1176-7 wichtig sind oder sein könnten wie z.B. Rechnung, Lieferschein oder Auftragsbestätigung, Montageanleitung und Wartungsanleitung im Original oder in einer Kopie an die zuständigen Stellen weiterleiten.

Bitte beachten Sie:

Um einen sicheren und unfallfreien Spielbetrieb mit diesem Gerät zu gewährleisten, müssen die im Wartungsplan aufgeführten Tätigkeiten unbedingt ausgeführt werden.

Vor dem Anziehen der Schraubverbindungen unbedingt alle Anbauteile einsetzen. Ein nachträgliches Einsetzen ist NICHT möglich!

FR

1. Déterminer l'emplacement de l'équipement en tenant compte de l'emprise au sol (zone de sécurité).
2. Effectuer les travaux de déblai selon schéma. Pour obtenir une stabilité maximale et une installation sûre, un niveau modéré de solubilité dans le sol est requis.
3. Versez une couche drainante de gravier d'env. 10 cm d'épaisseur entre le bas des poteaux et la base de la fondation.
4. Placer les poteaux dans les trous de fondation respectifs.
5. Visser les composants sans serrer.
6. Pour installer les composants pré-assemblés ou les pièces individuelles, les vis doivent être légèrement graissées avec la pâte de montage fournie. Serrez toutes les vis uniquement après l'alignement.
7. Remplir les fondations de béton comprimé C20 / 25 et recouvrir d'un matériau qui répond aux exigences d'amortissement de sorte que la hauteur de chute critique du revêtement soit égale ou supérieure à la hauteur de chute libre de l'équipement (selon EN 1176-1).
8. Ne permettre l'accès au jeu uniquement après la prise complète du béton.
9. Selon les instructions d'entretien, vérifiez tous les raccords à vis après 4 à 5 semaines et resserrez-les si nécessaire.
Veuillez vous assurer que tous les outils spéciaux fournis (par exemple, clé Allen pour vis Allen sécurisées, etc.) et tous les documents spécifiques qui sont ou peuvent être utiles pour la gestion de la sécurité selon EN 1176-7 (par exemple facture, bon de livraison, confirmation de commande, instructions d'installation, instructions de maintenance) sont transmis au personnel compétent.

Attention:

Afin d'assurer un fonctionnement sûr et sans accident du jeu, il est essentiel d'exécuter les opérations répertoriées dans le calendrier de maintenance.

Avant de serrer les raccords à vis, assurez-vous d'utiliser tous les accessoires. L'insertion ultérieure n'est PAS possible!

Dimensions de l'équipement

8,43 x 12,59 x 2,93 m

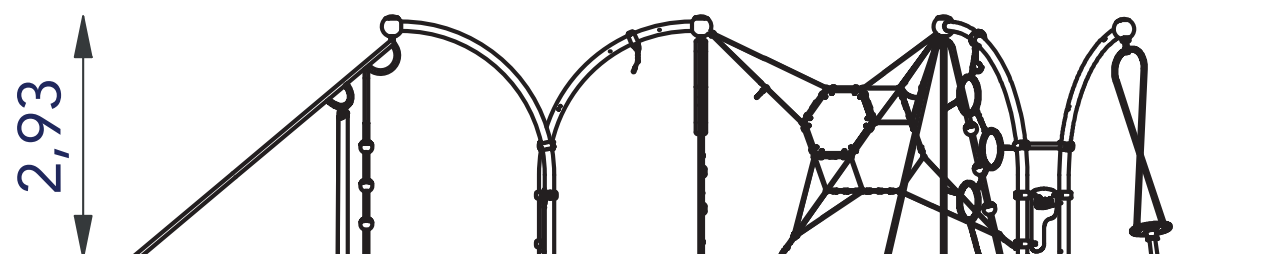
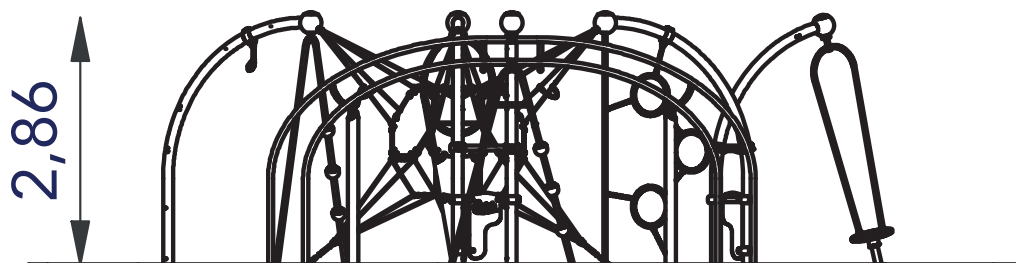

Espace minimum

11,48 x 15,56 x 2,93 m

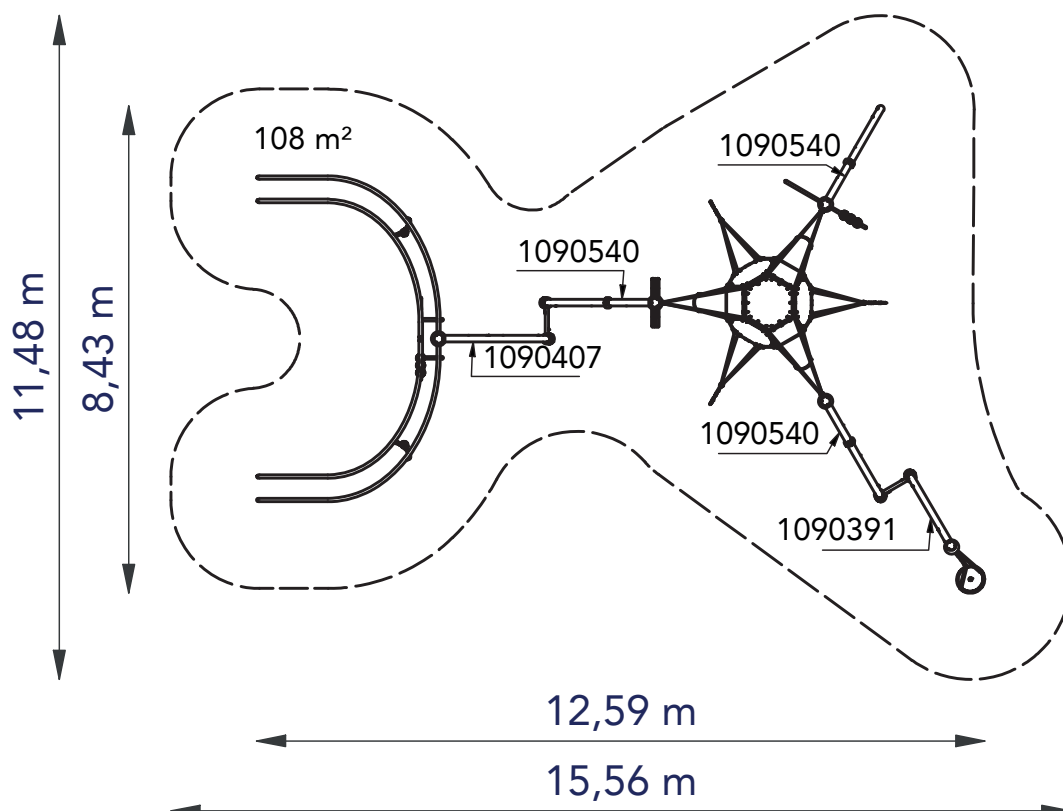

Plan de fondation



Fondations (sur site)

Quantité de béton (approx.)

5,00 m³

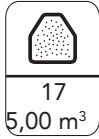

17
5,00 m³

- A- 2x 1,70 x 1,00 x 0,50 m
- B- 2x 1,00 x 0,80 x 0,50 m
- C- 1x 1,30 x 0,50 x 0,50 m
- D- 12x 0,60 x 0,60 x 0,50m

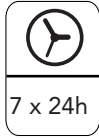

7 x 24h



Tout d'abord, installez et alignez tous les composants et serrez toutes les vis. Ensuite, préparez les fondations avec du béton comprimé C20/25 selon le plan.

Pour les jeux de cordes et les carrousels, une exception s'applique : le montage des éléments de corde et des carrousels n'a lieu qu'après la prise des fondations en béton.

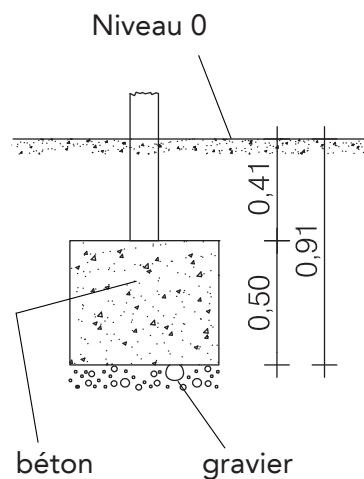

Plan de fondation

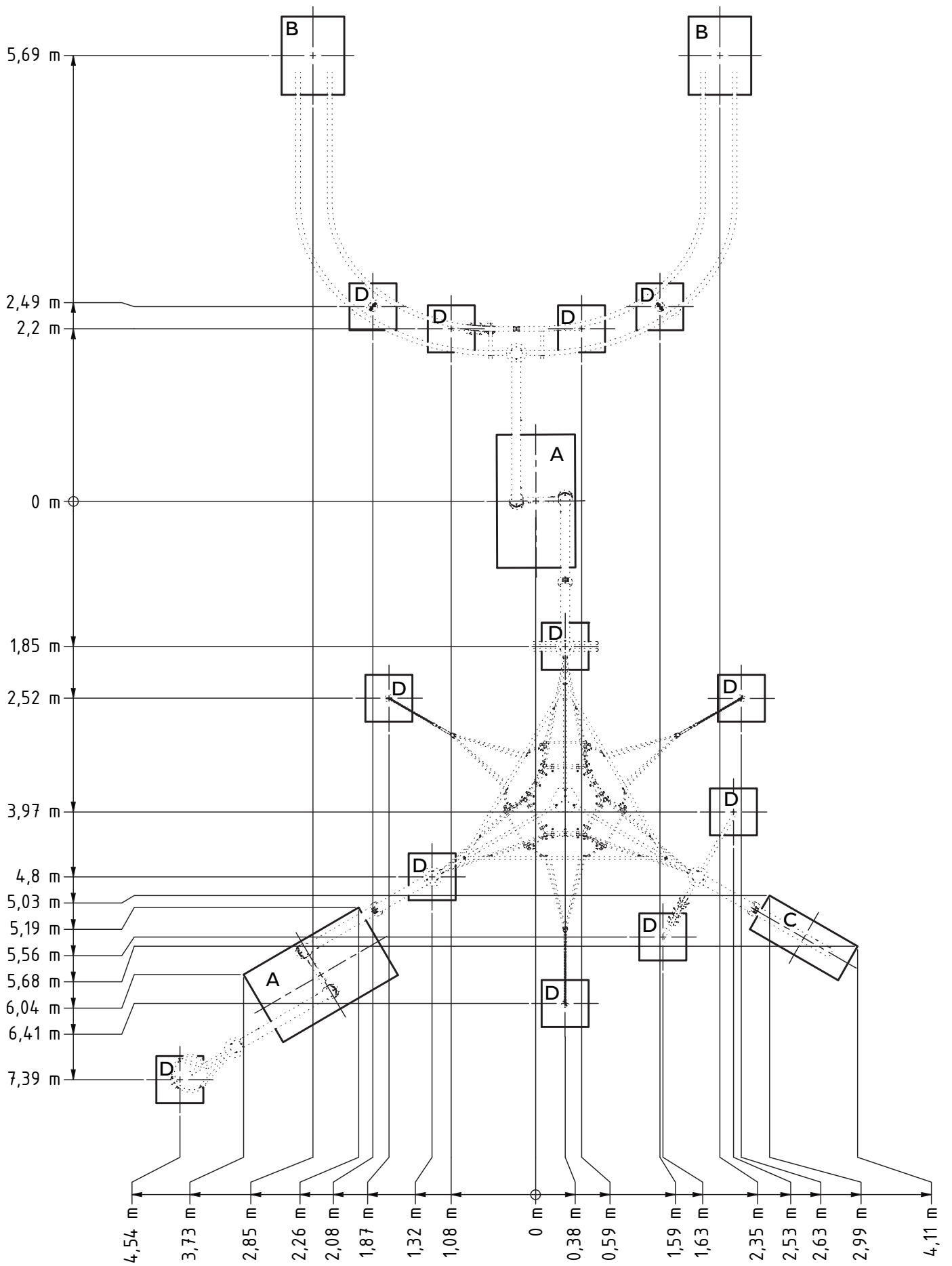

ompo ant

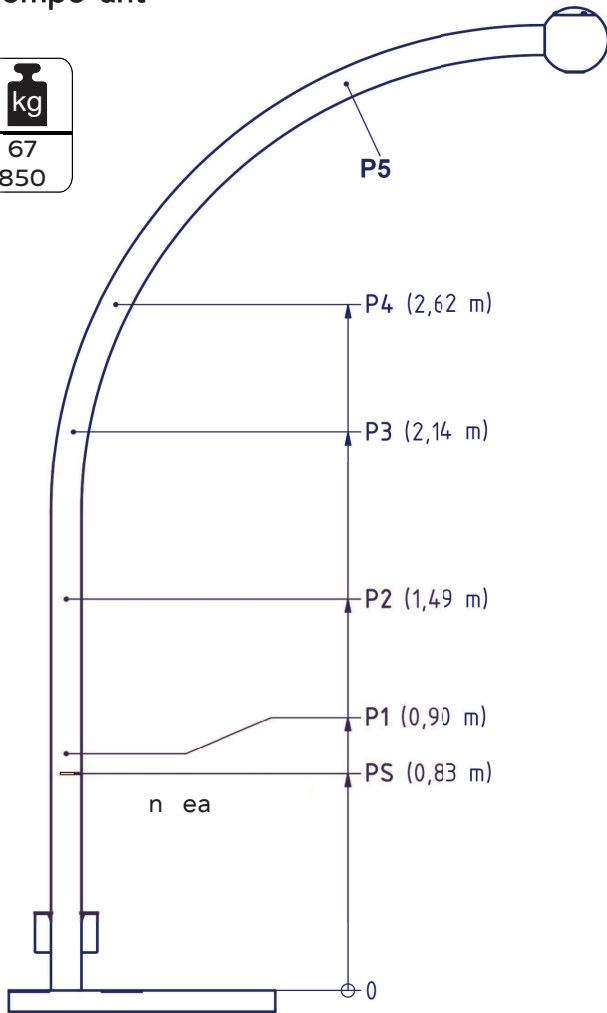
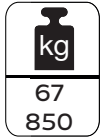

Art.: 1090407
1x

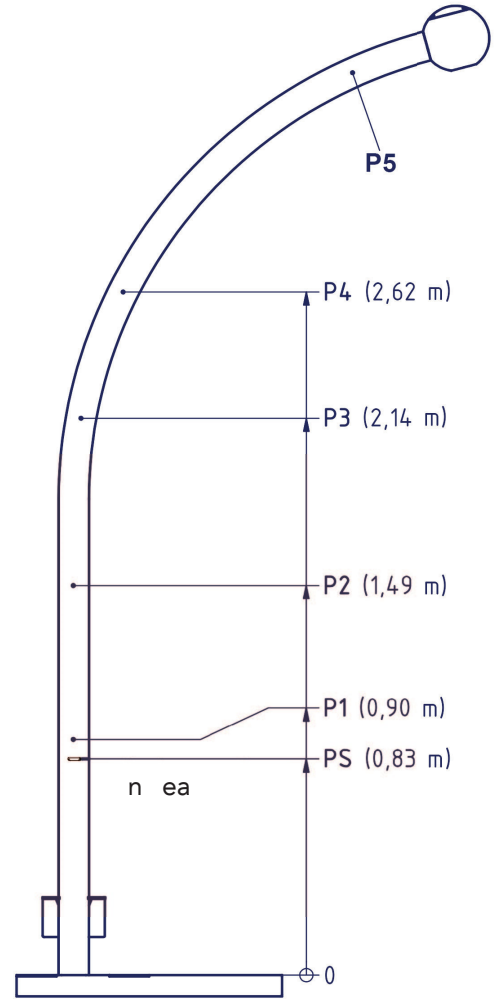

Art.: 1090391
1x

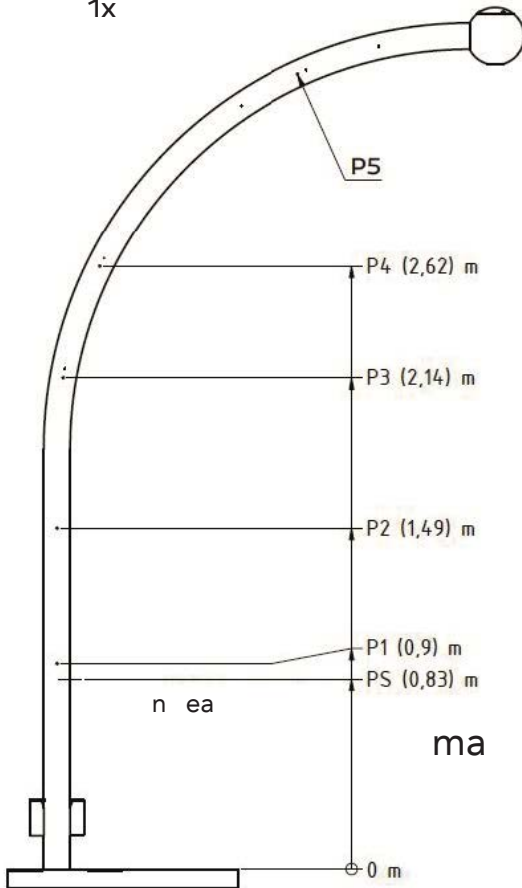

Art.: 1090540
3x

ma age n ea



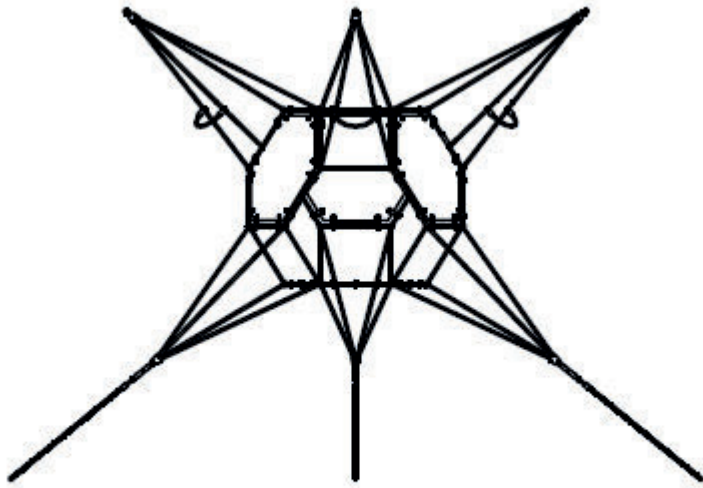

1090541
1x

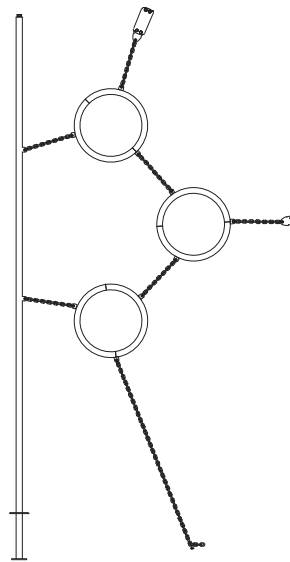

1090417
1x

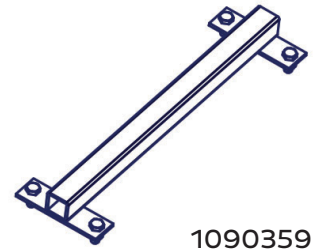

1090359
4x

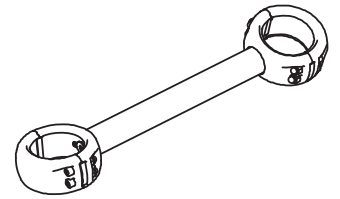

1090368
2x

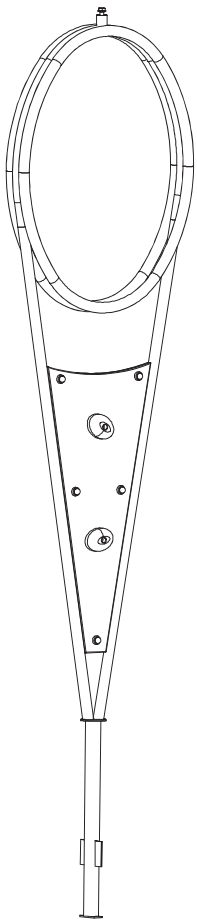

1090371
1x

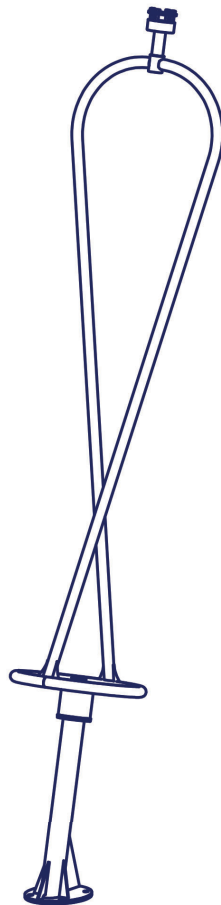

1090343
1x

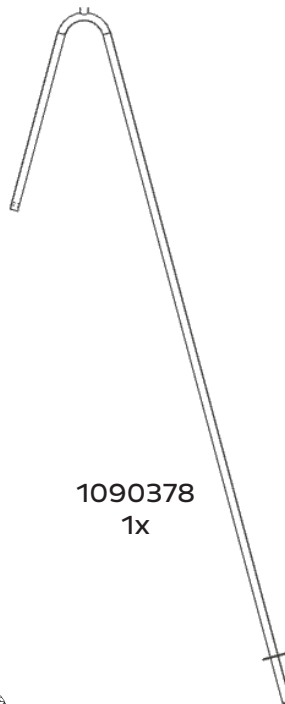

1090378
1x

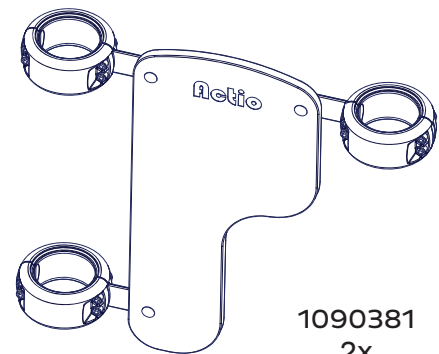

1090381
2x

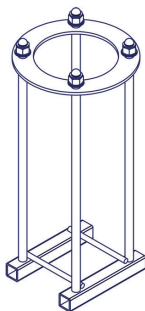

1090393
1x



1090448
2x

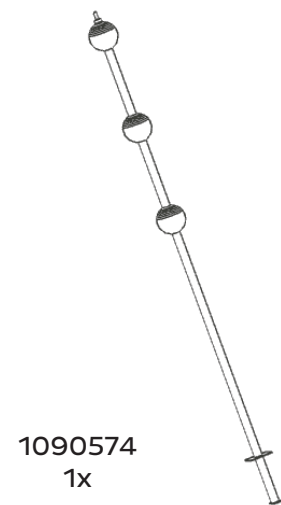

1090574
1x

ompo ant

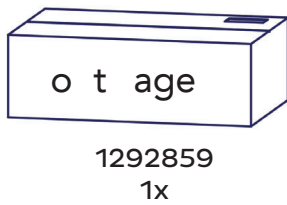
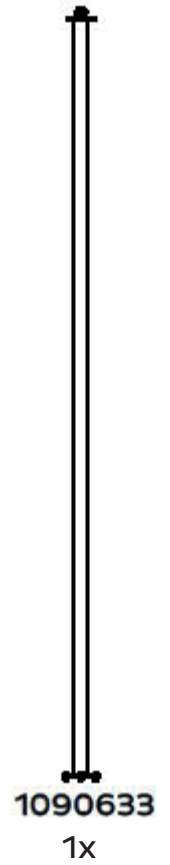
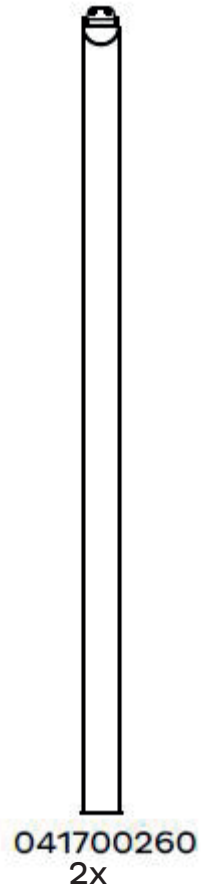
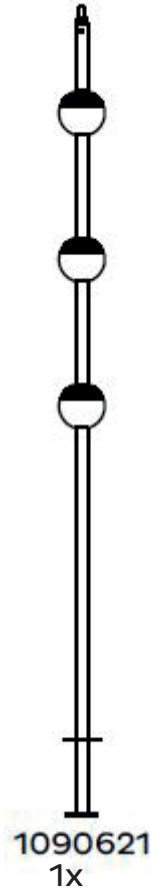
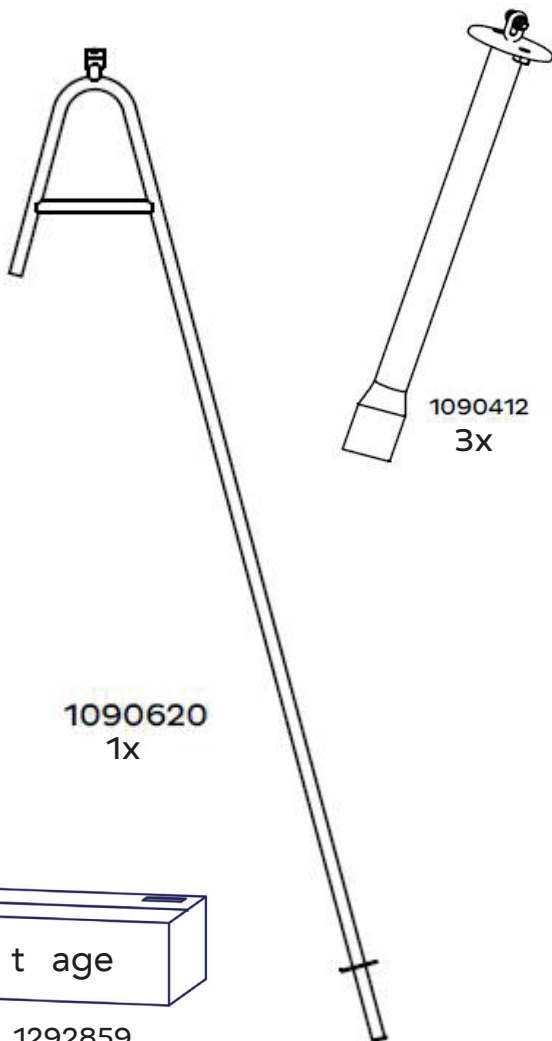
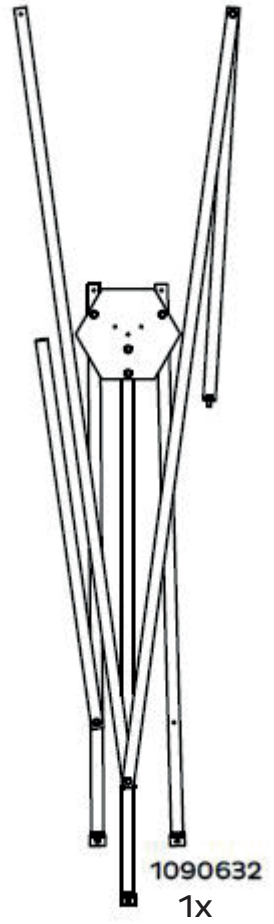
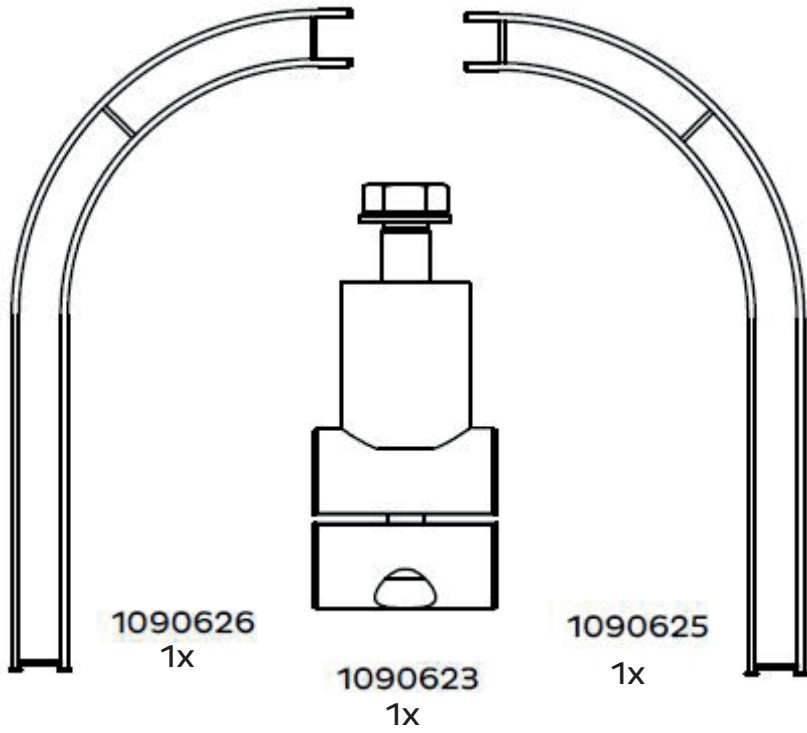

tape



24 mm



T40



8 mm

min.
2,5 m

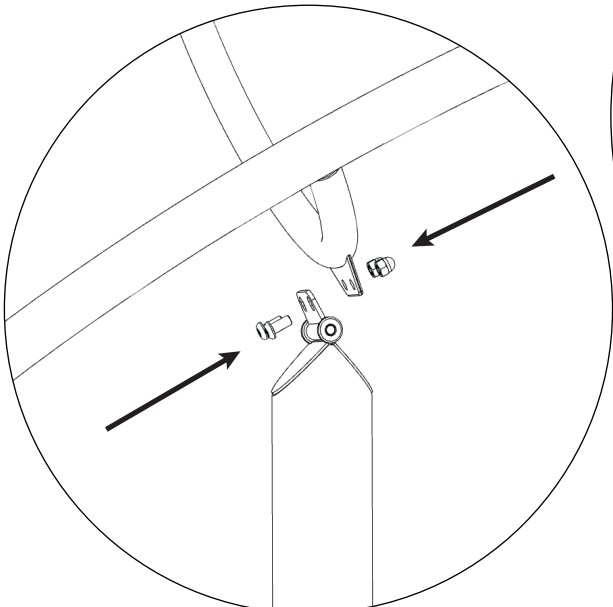
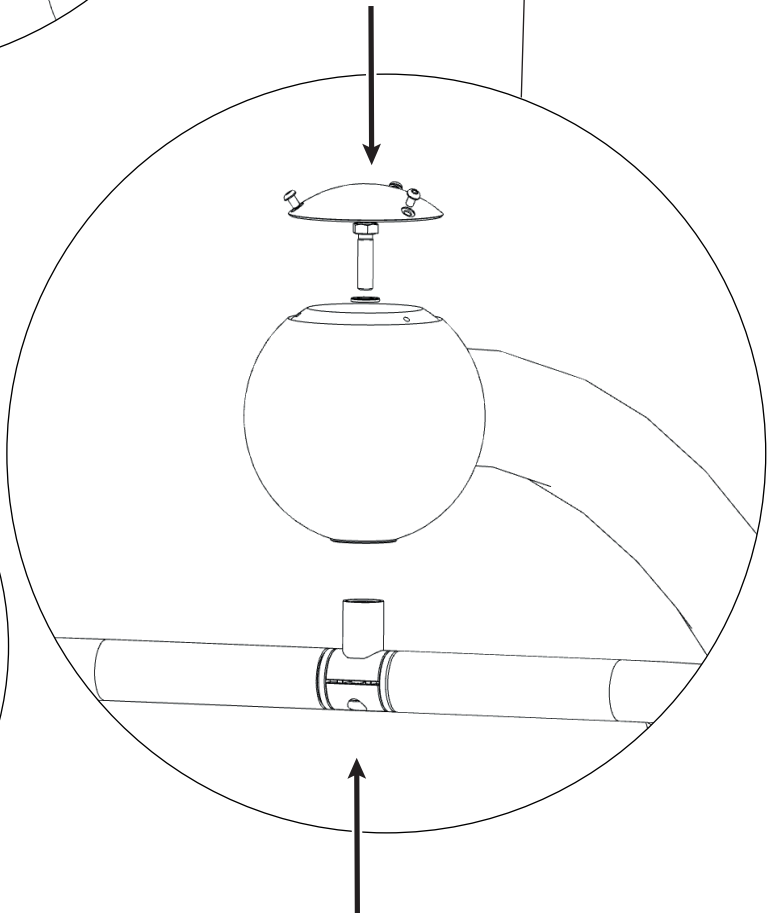
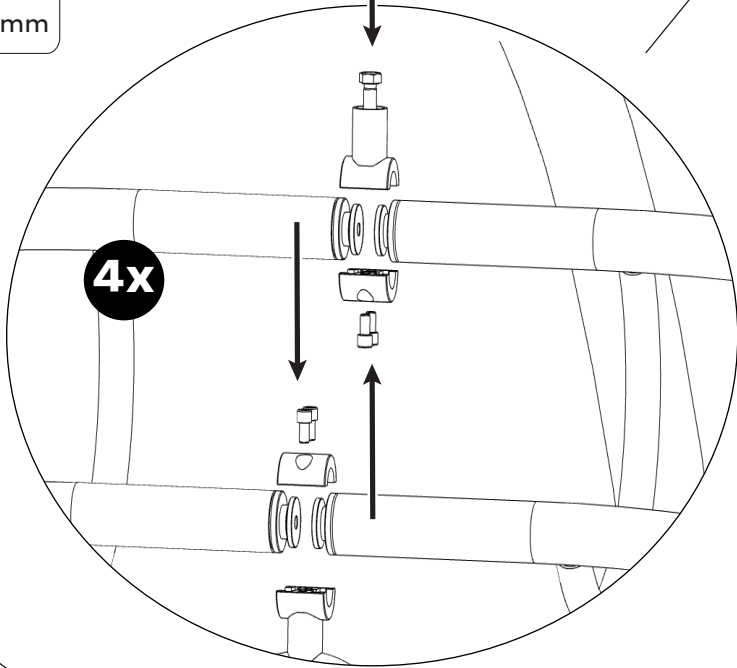
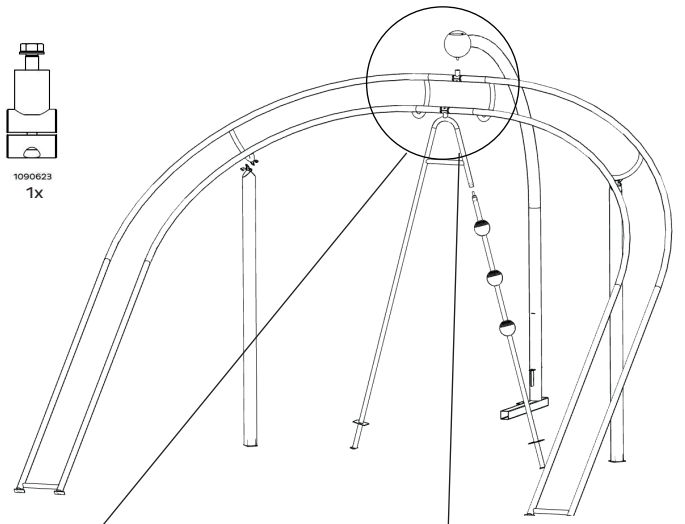
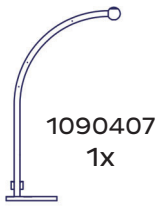
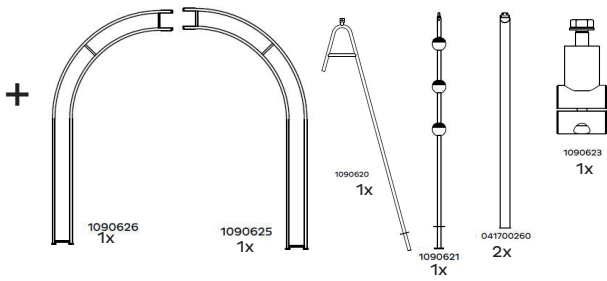

tape



19 mm

1090540
1x

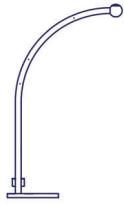

1090359
2x

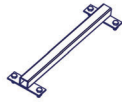

playing surface
ATTENTION

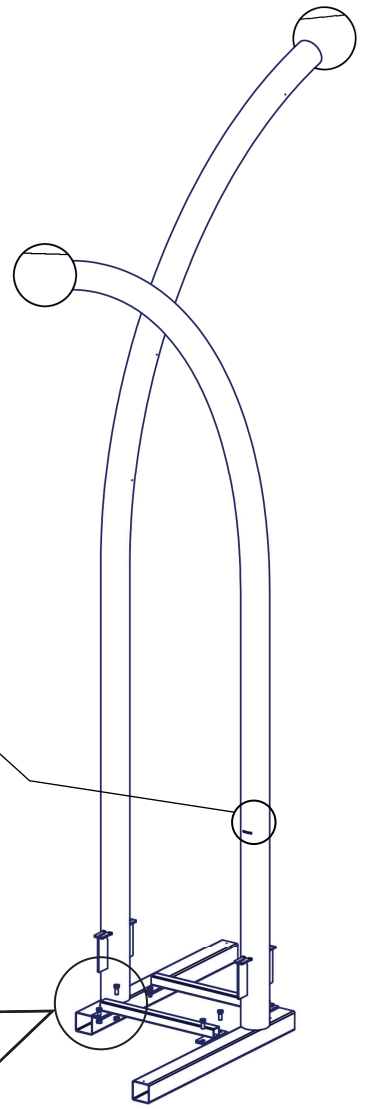

4x

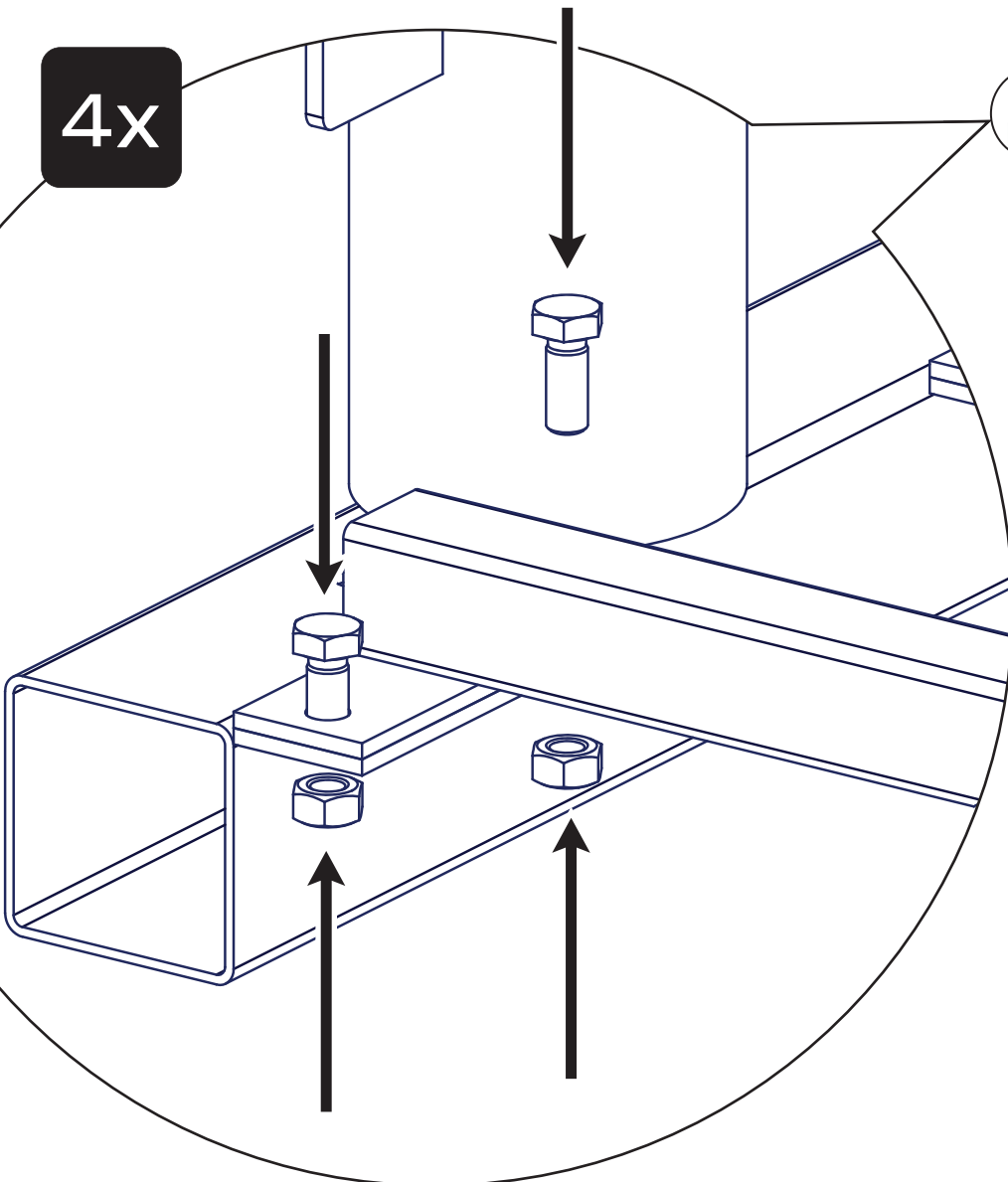

tape

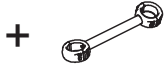
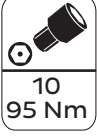

1090368
1x

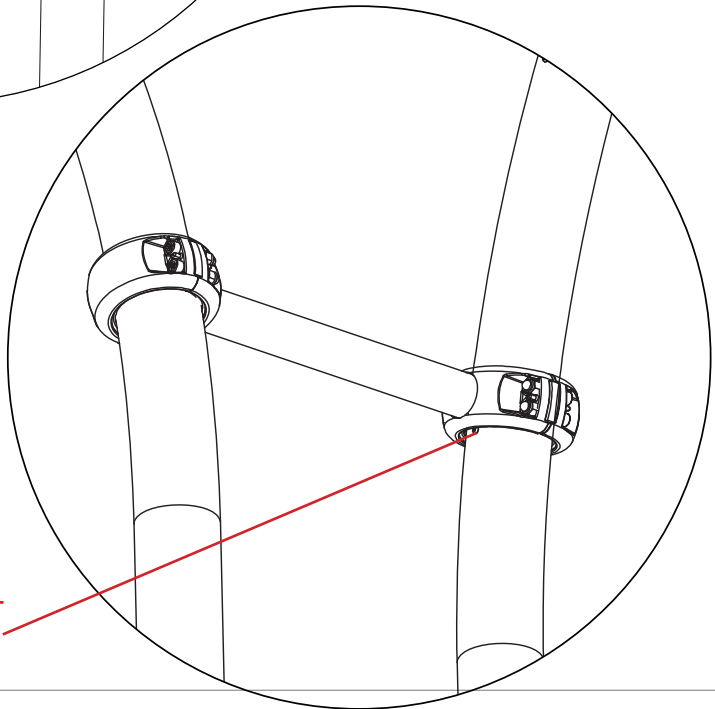
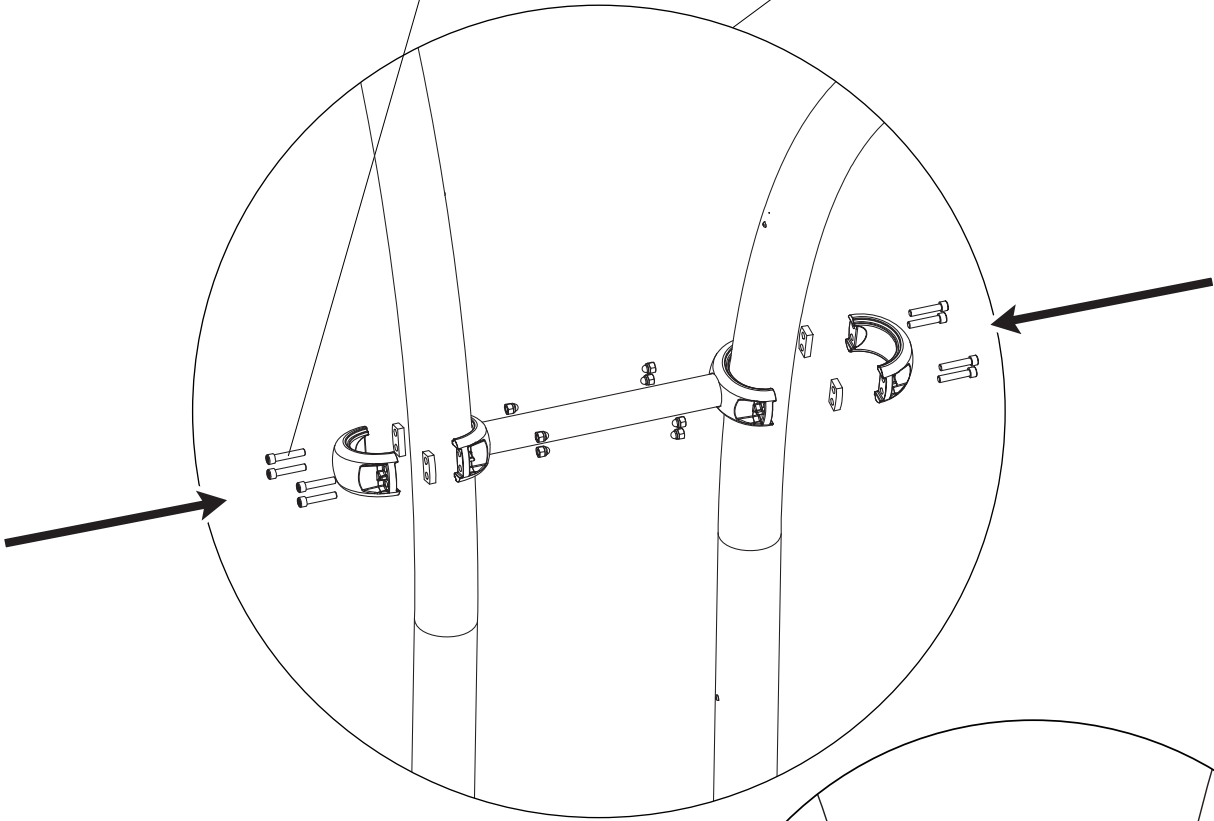
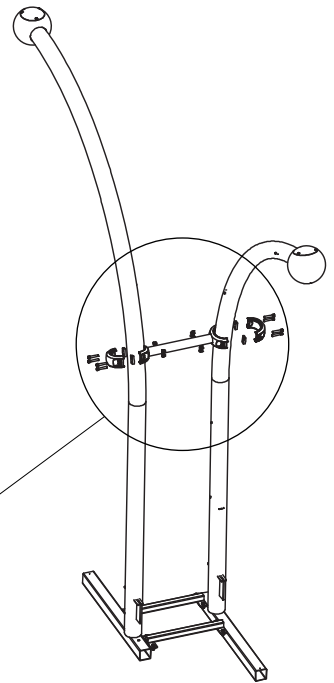

n ea
ATTENTION

tape

+

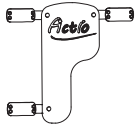

1090381
1x



pâte de
montage

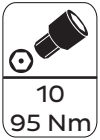

10
95 Nm

12x

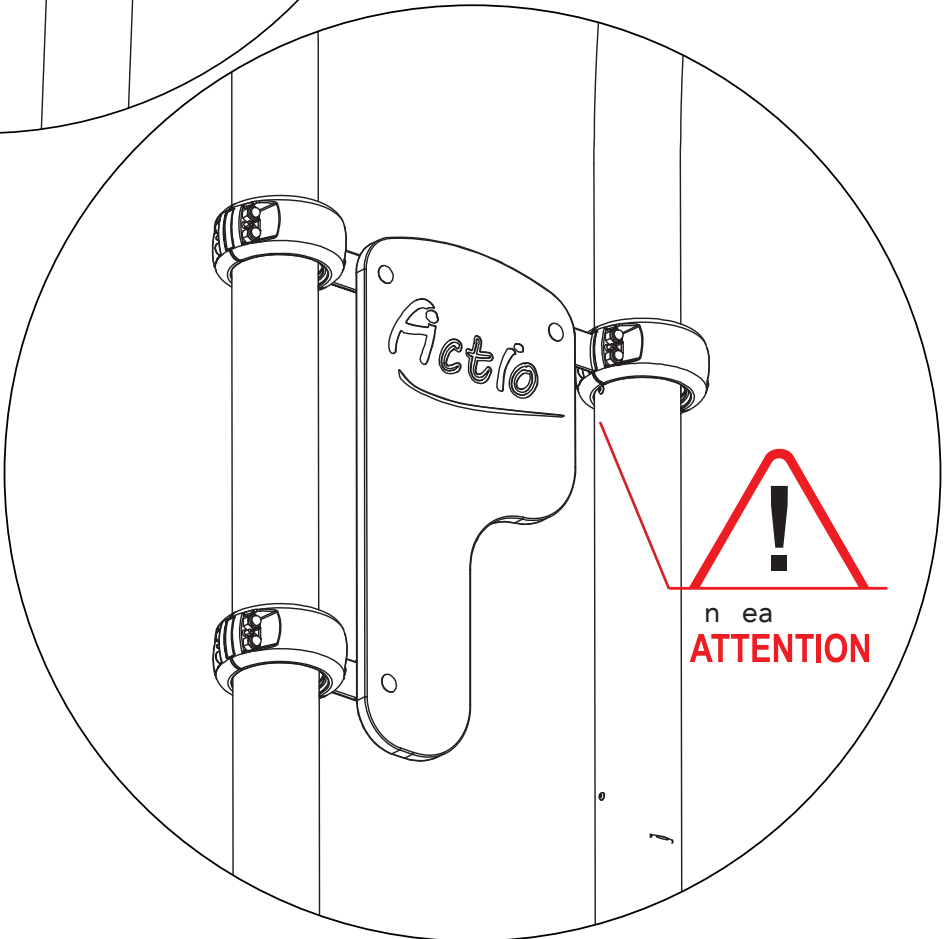
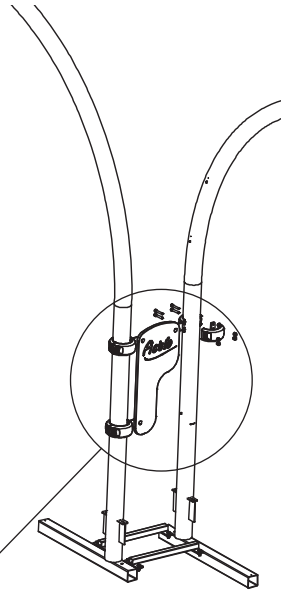
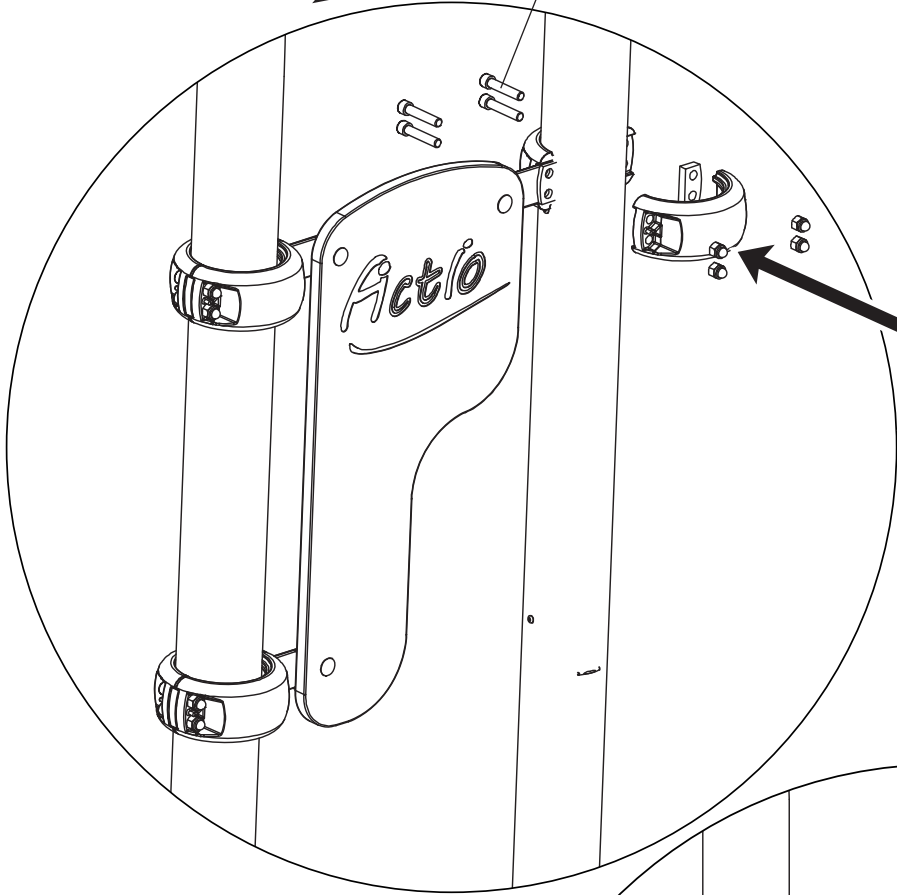

tape



24 mm



min. 2,5 m



T40

+

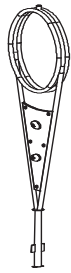

1090371
1x



pâte de montage

1x

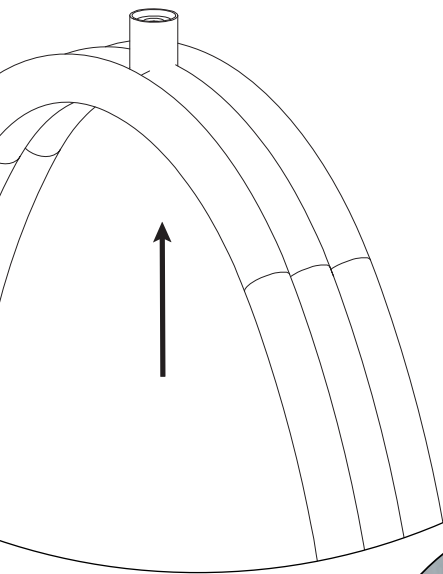
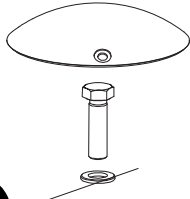

playing surface
ATTENTION

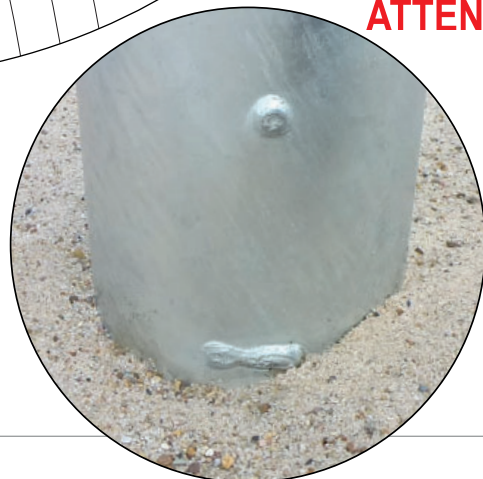

tape



+

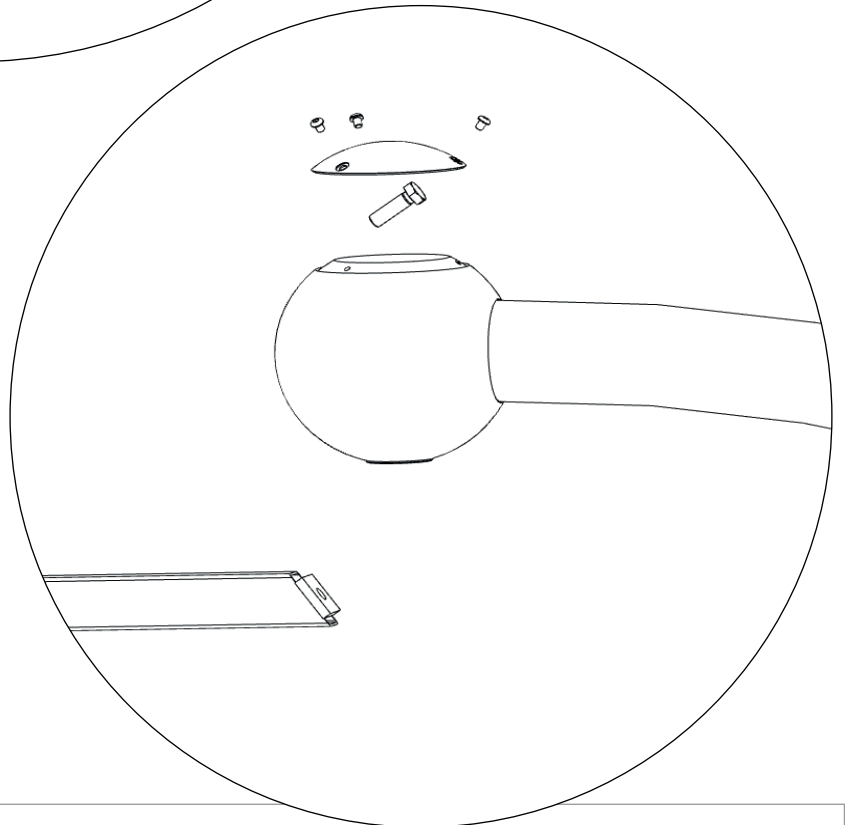
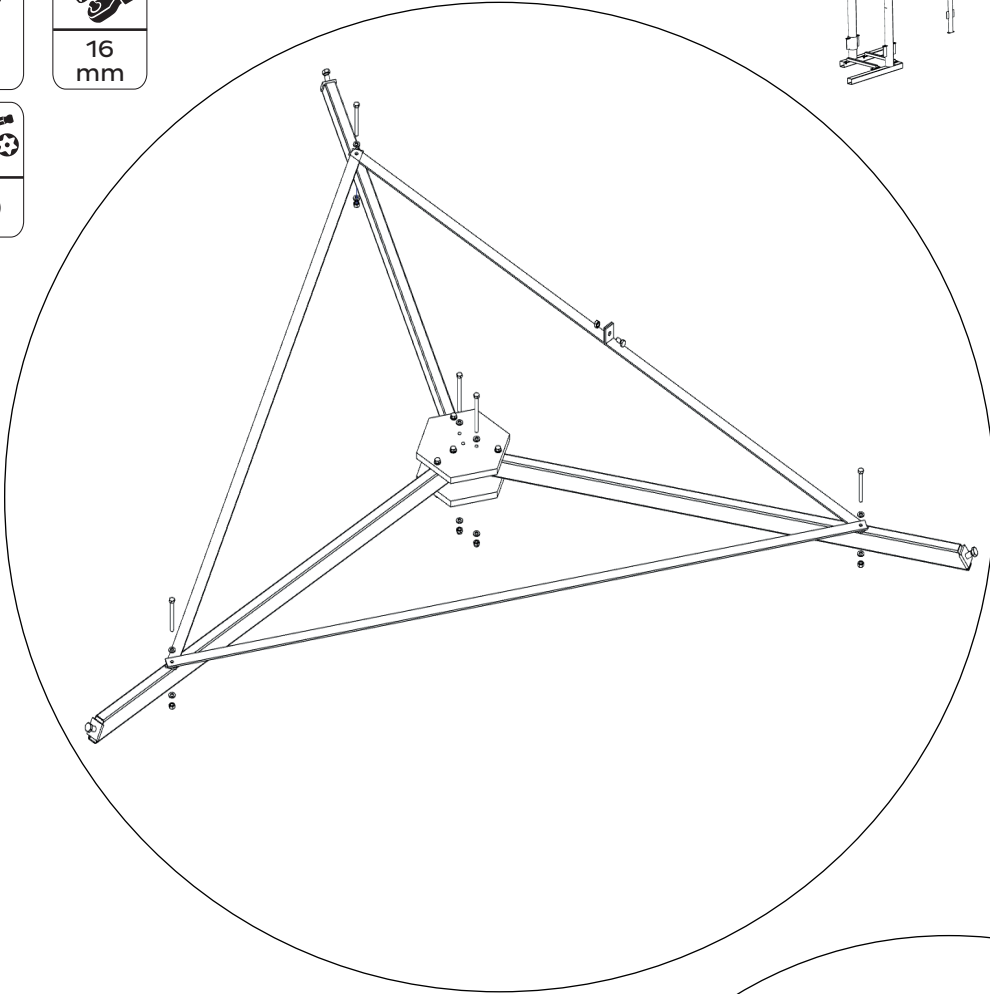
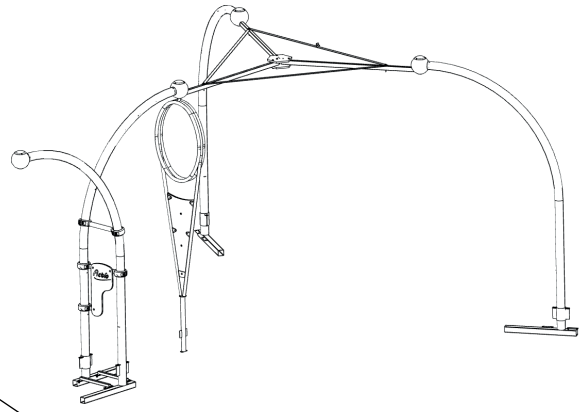
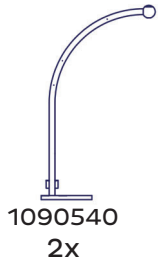
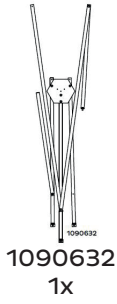

tape

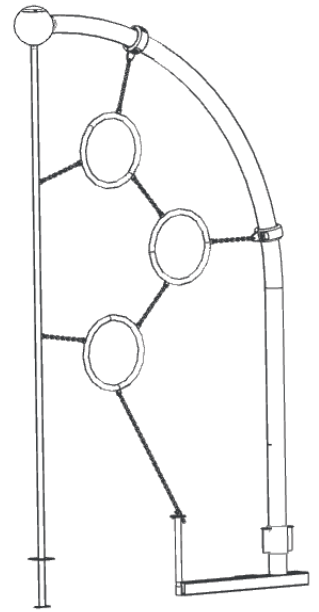
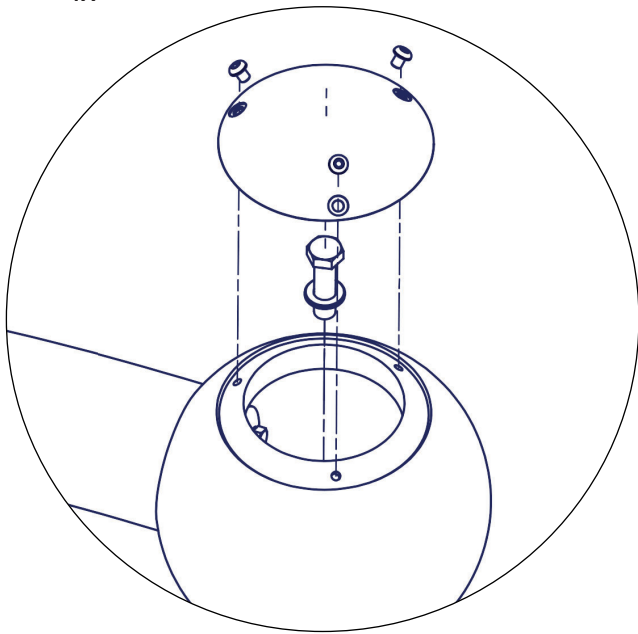
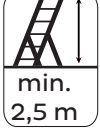
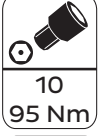
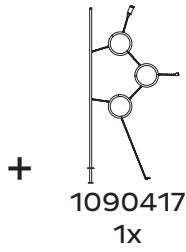

n ea
ATTENTION

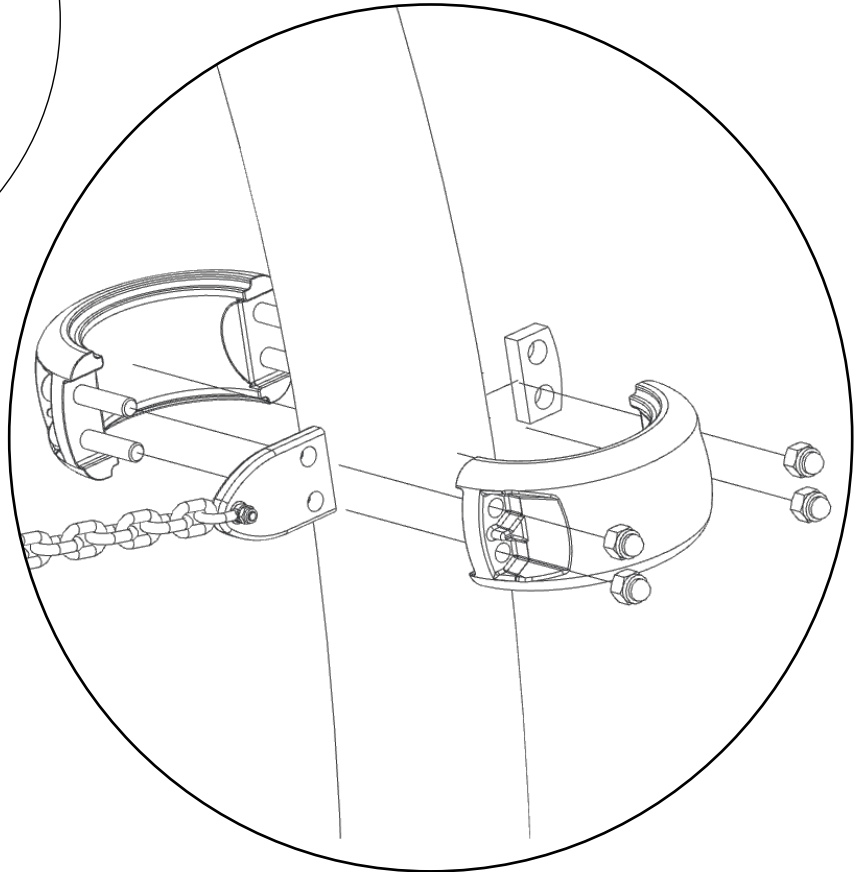
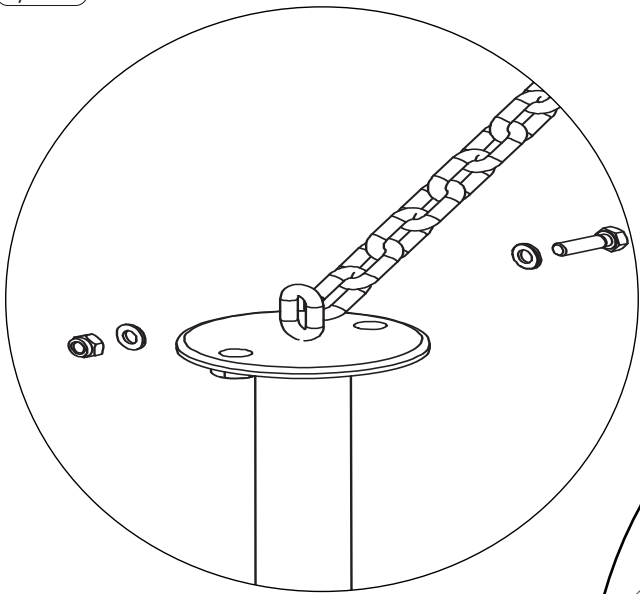

tape

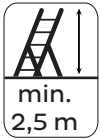

+

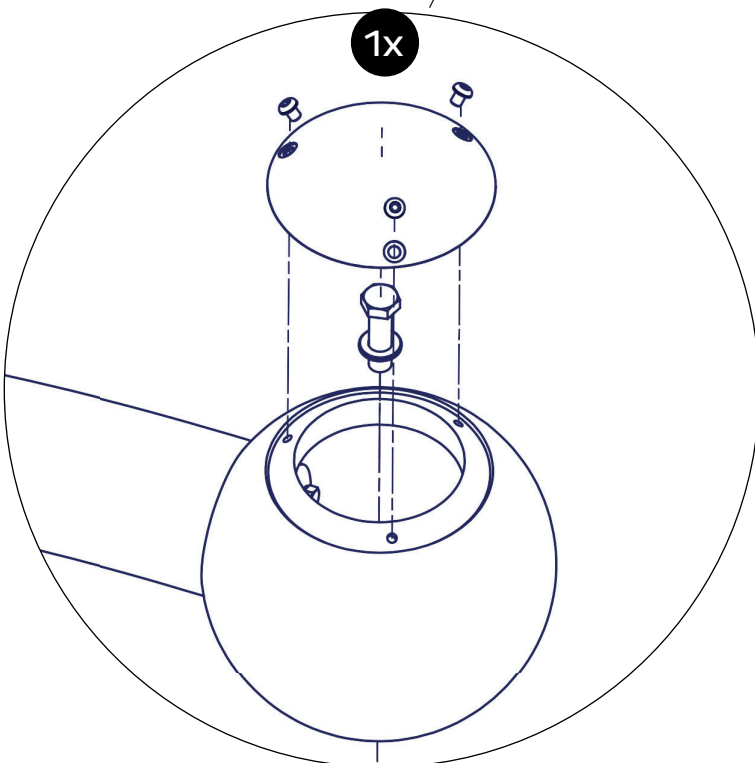
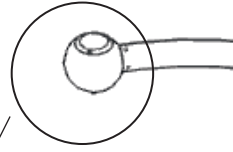
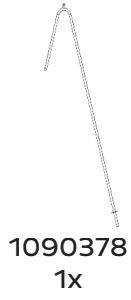

tape

10
95 Nm

+
1090448
2x

pâte de montage

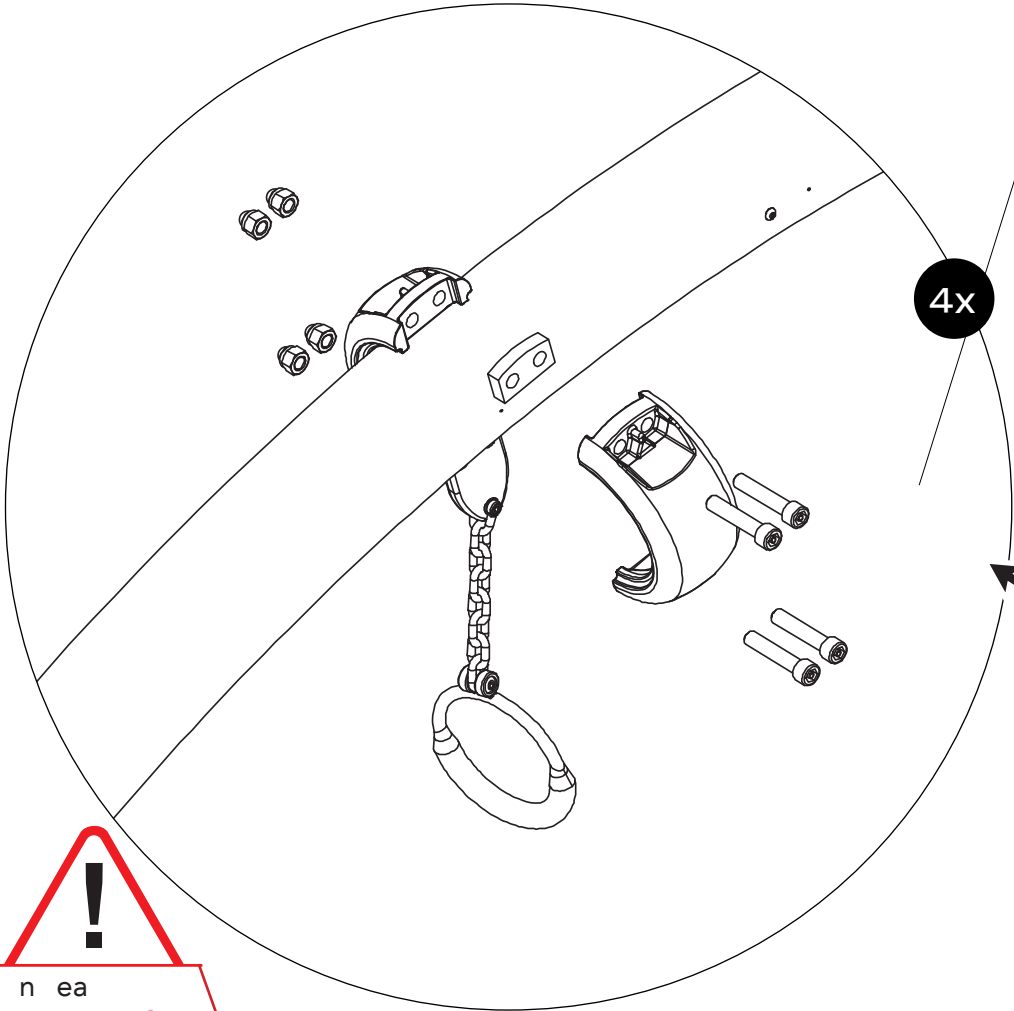

!
n ea
ATTENTION

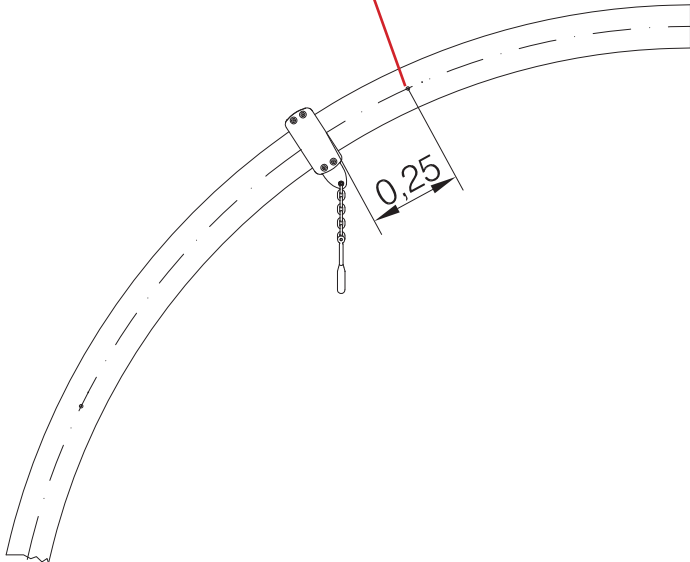

tape

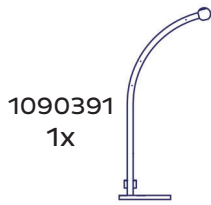

1090391
1x



1090359
2x



playing surface
ATTENTION

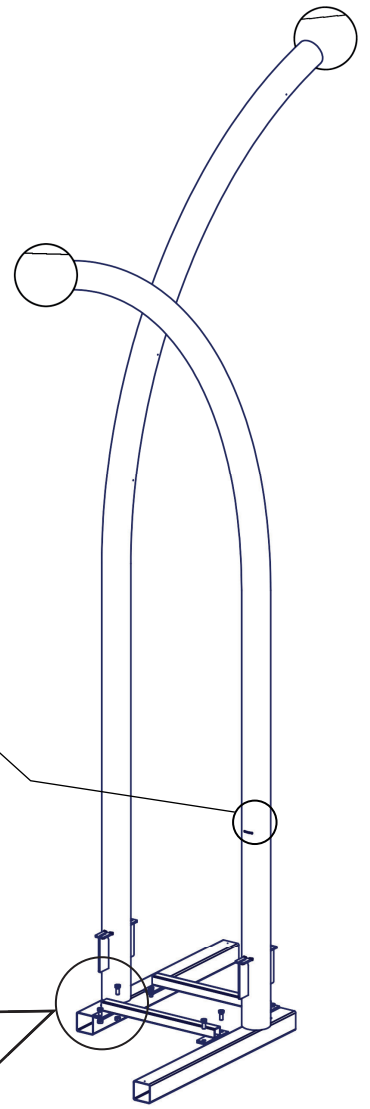

4x

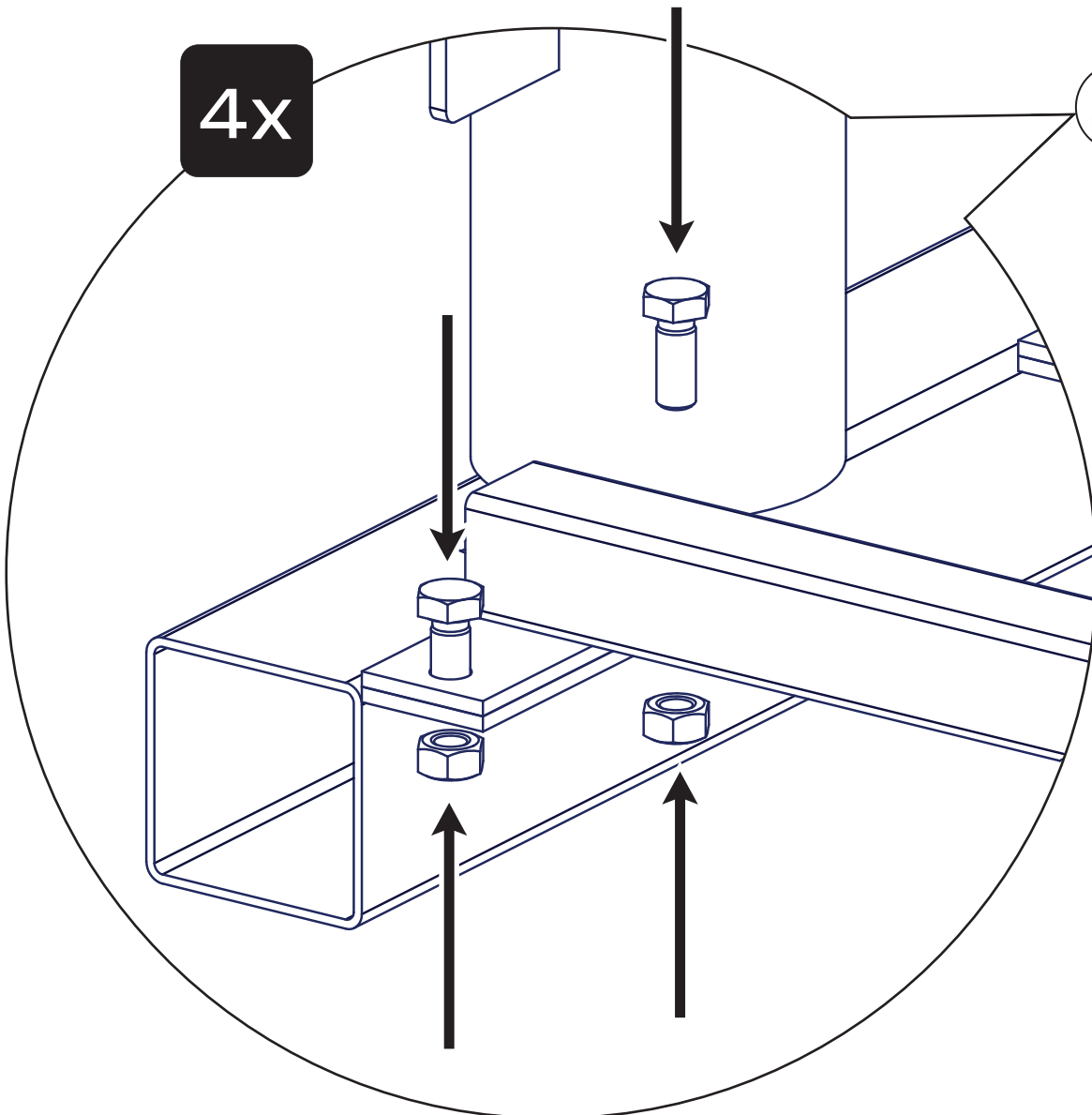

tape

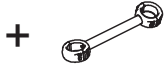
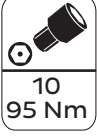

1090368
1x



pâte de
montage

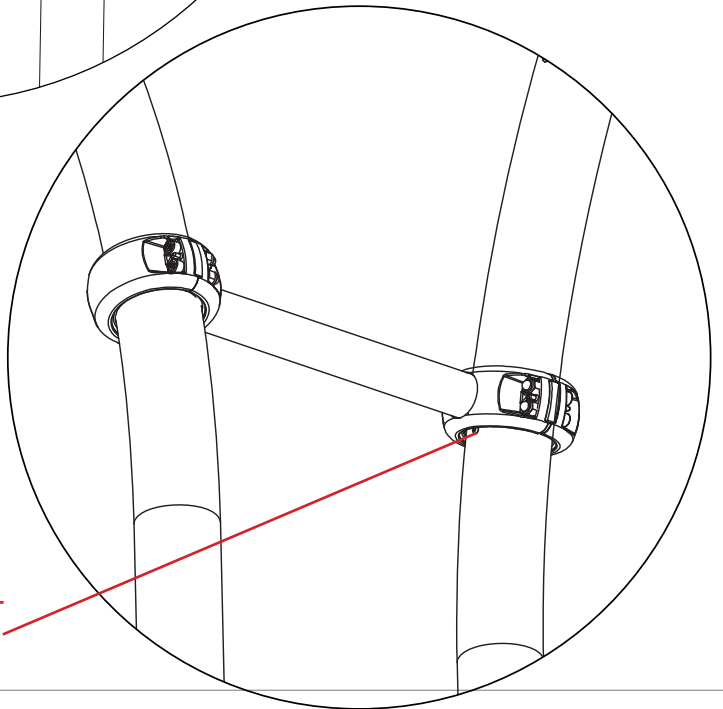
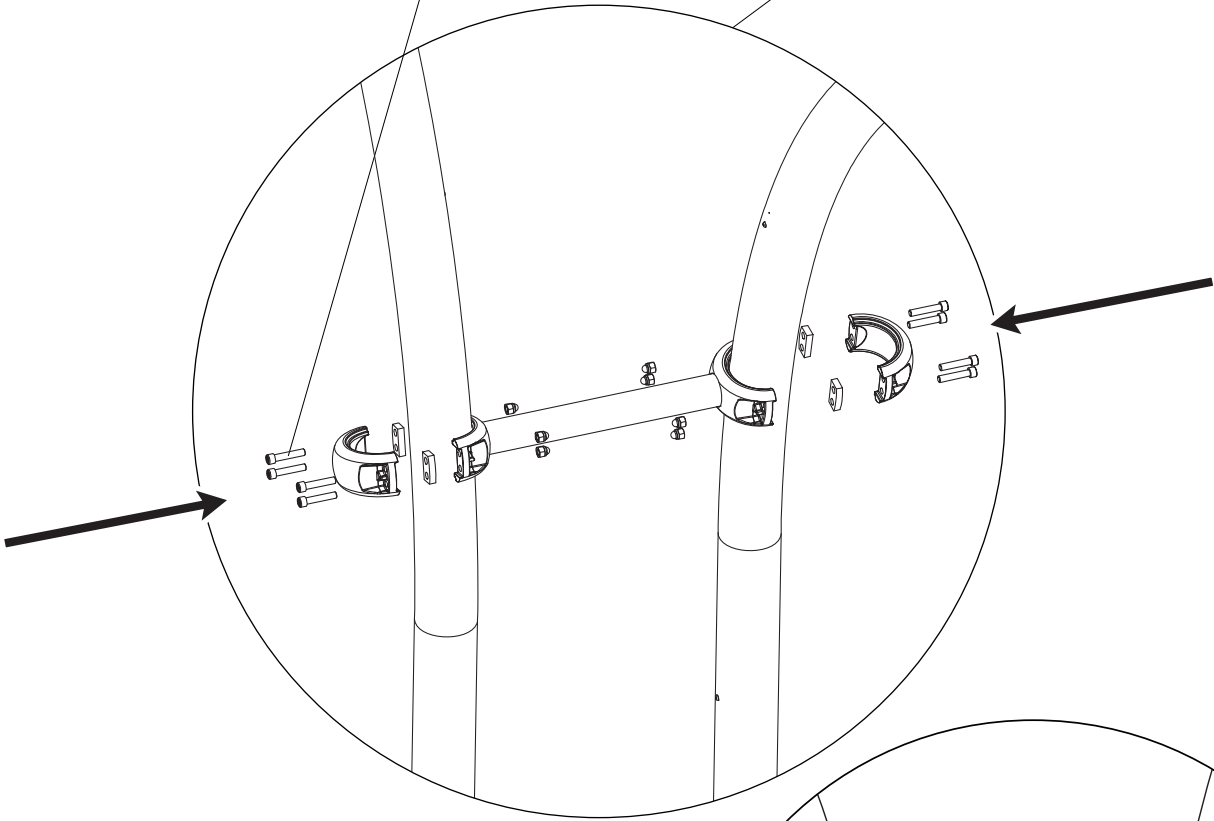
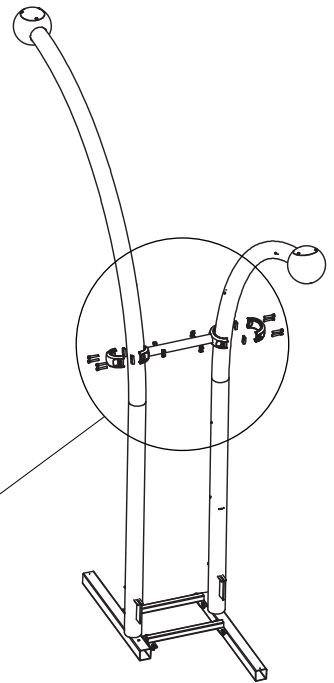

n ea
ATTENTION

tape

+

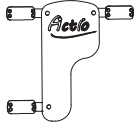

1090381
1x

pâte de
montage

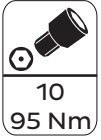

10
95 Nm

12x

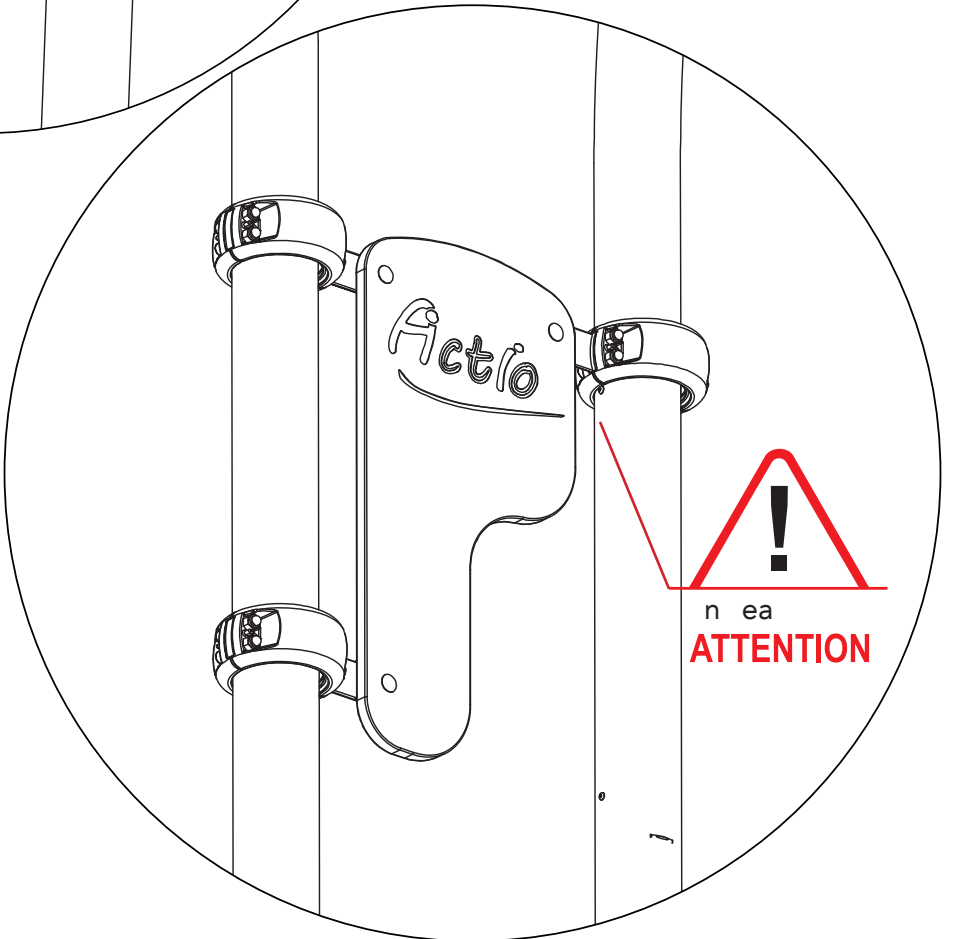
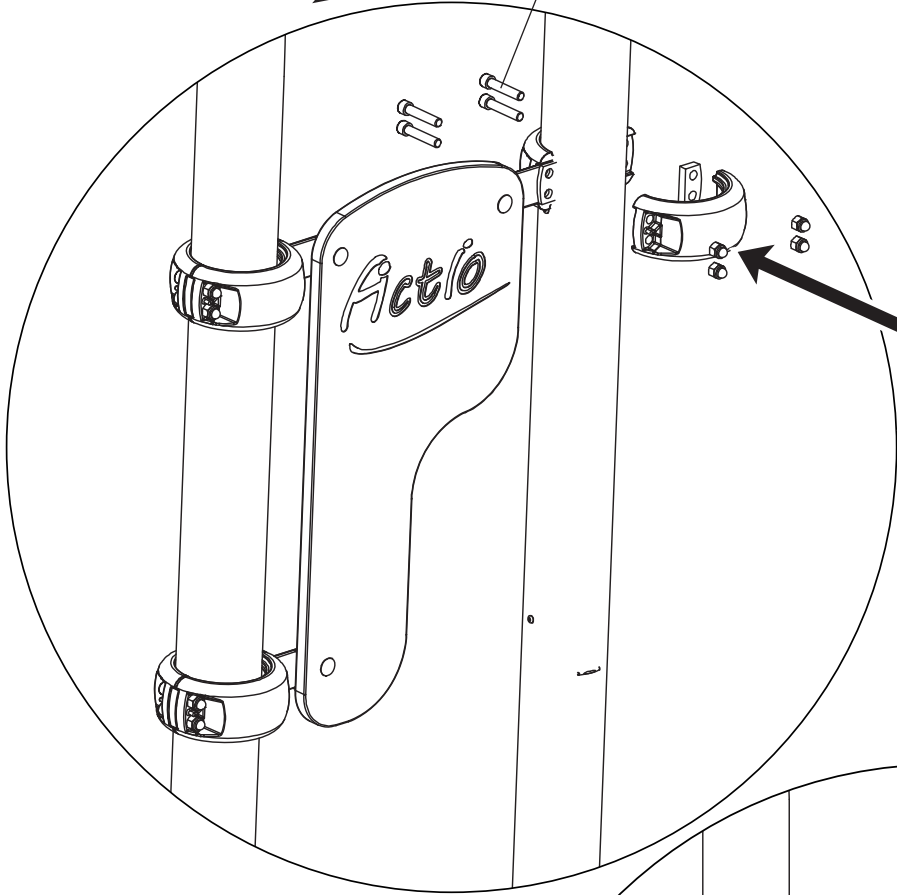

tape



24 mm



T40



8 mm



min.
2,5 m

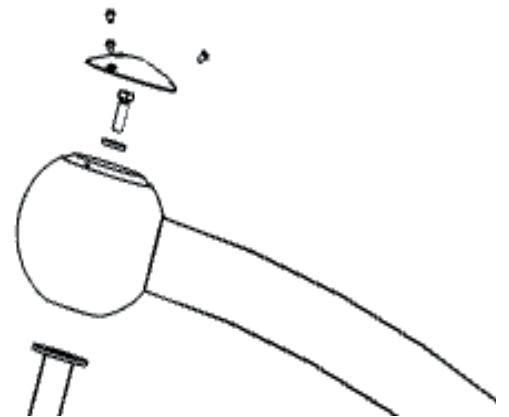
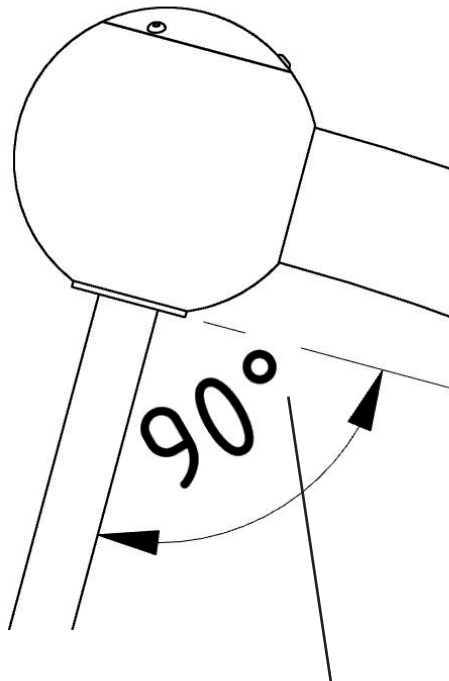
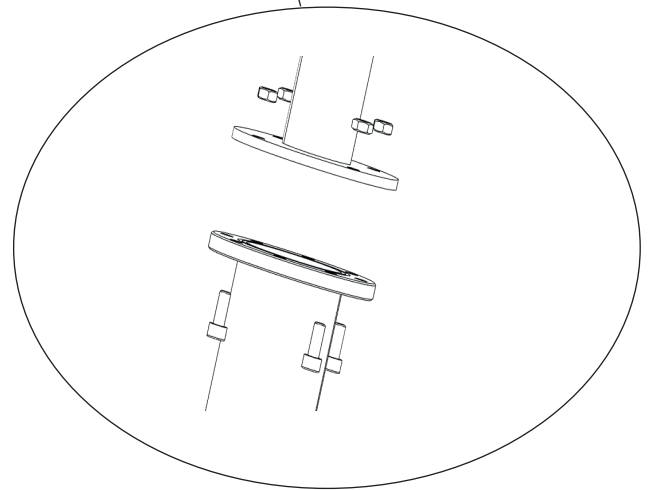
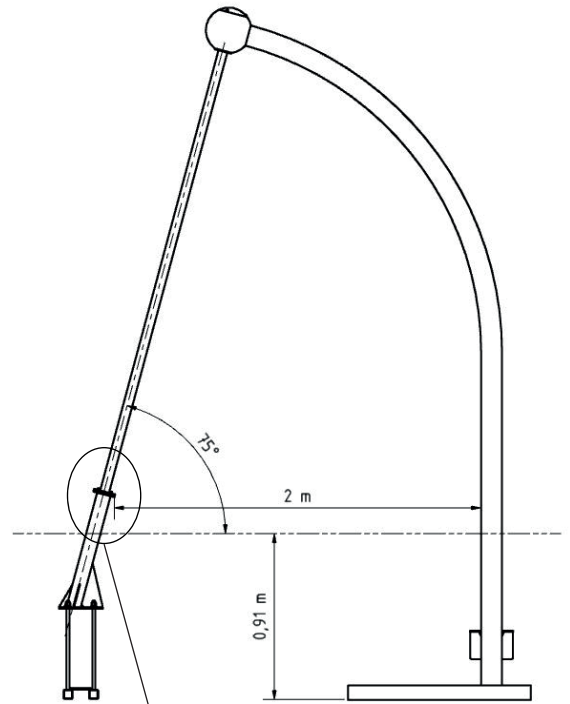
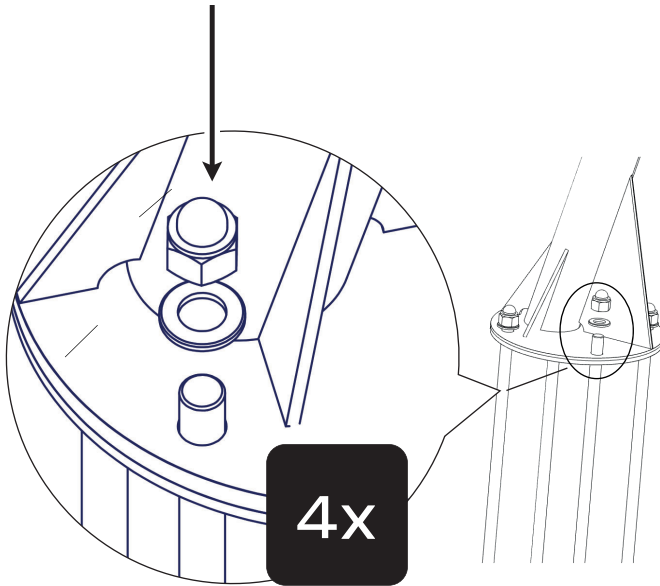
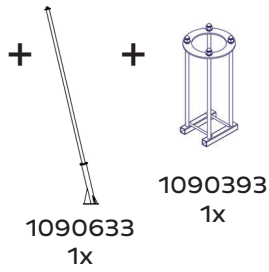

tape

+

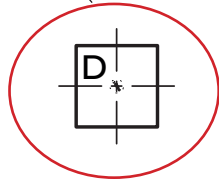
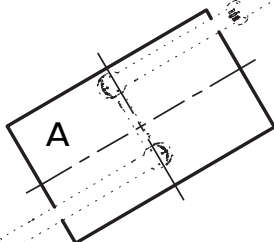
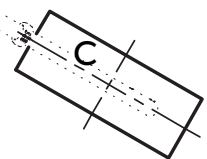
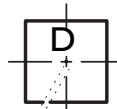
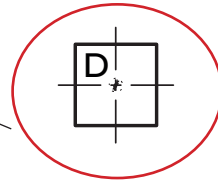
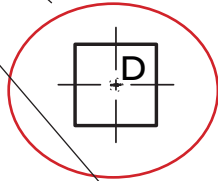
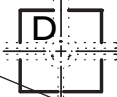
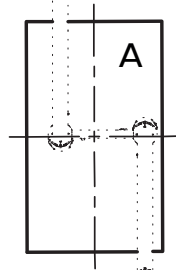
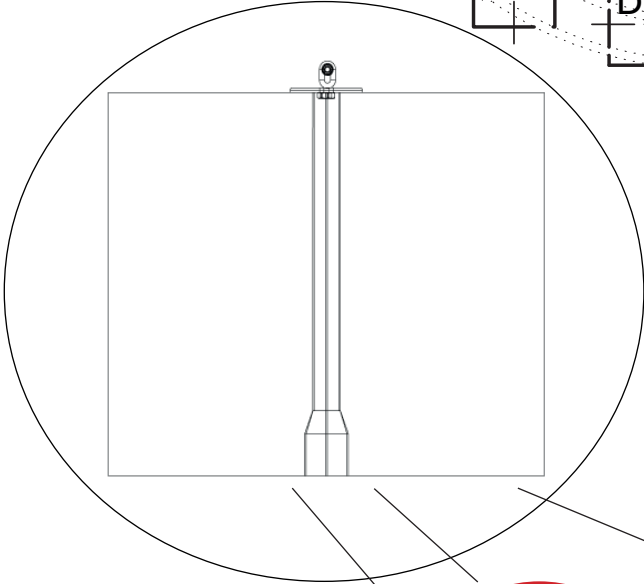
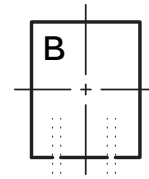
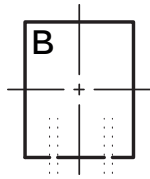
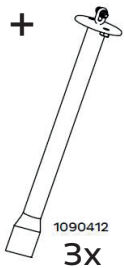

tape

+

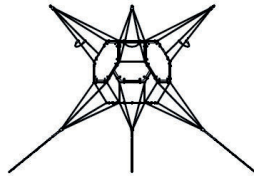

1090541
1x

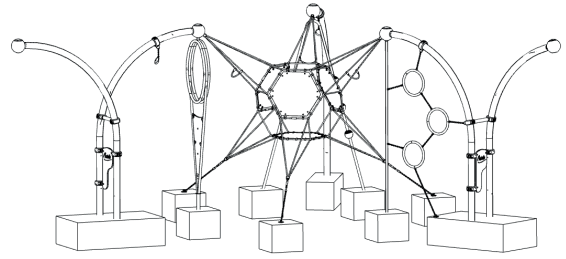

min.
2,5 m



T40



10
95 Nm



16 mm

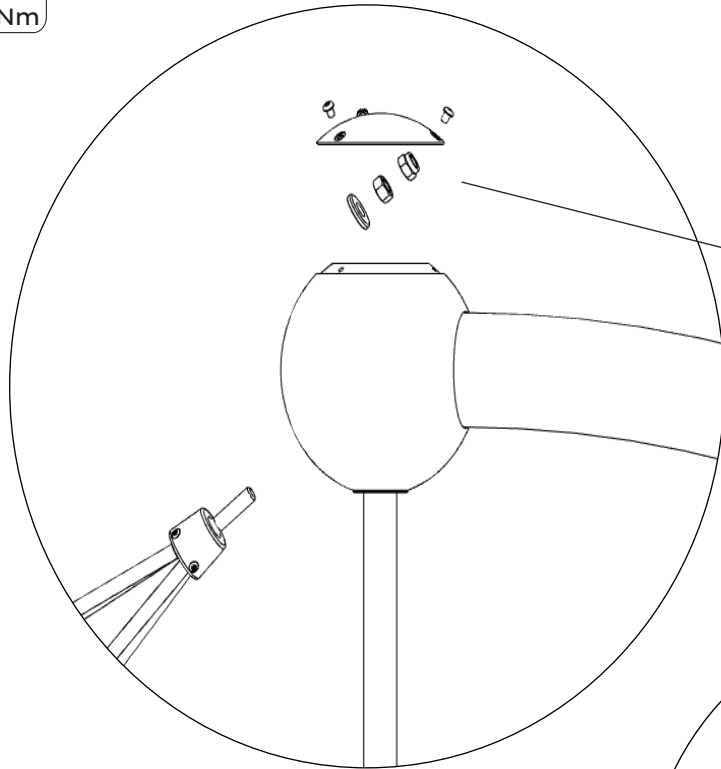

pâte de
montage

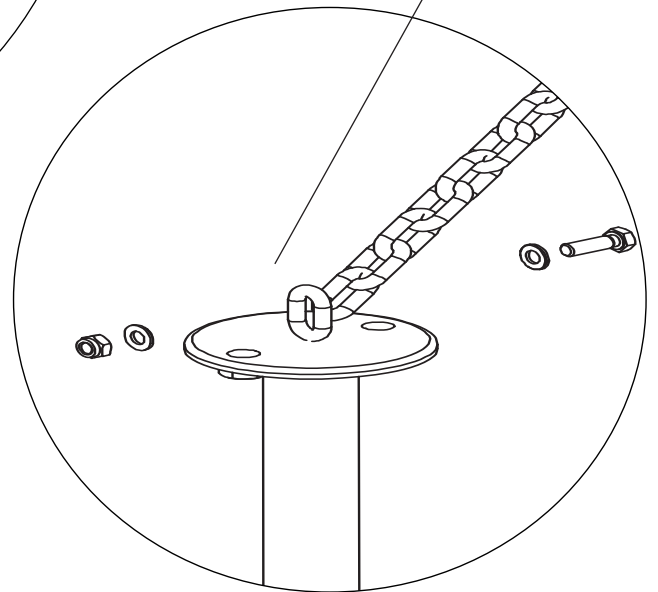

tape



T40



8 mm



min.
2,5 m

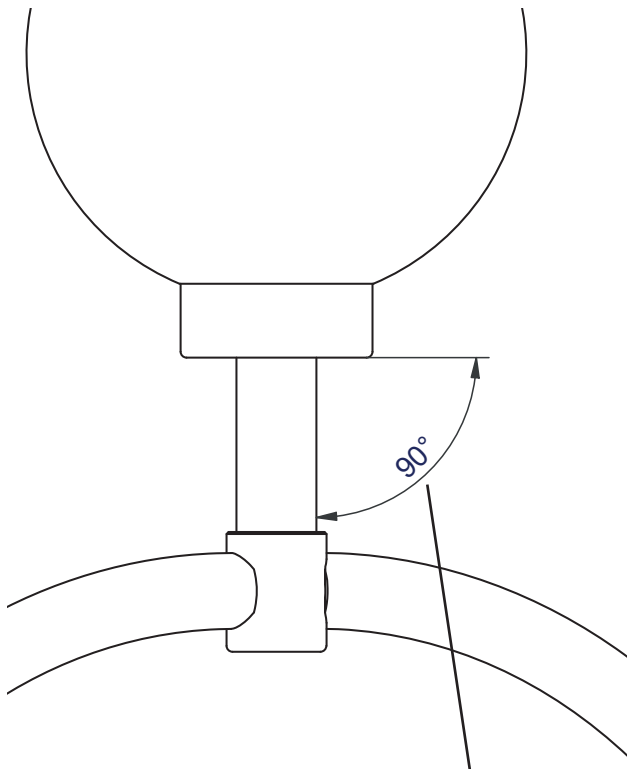
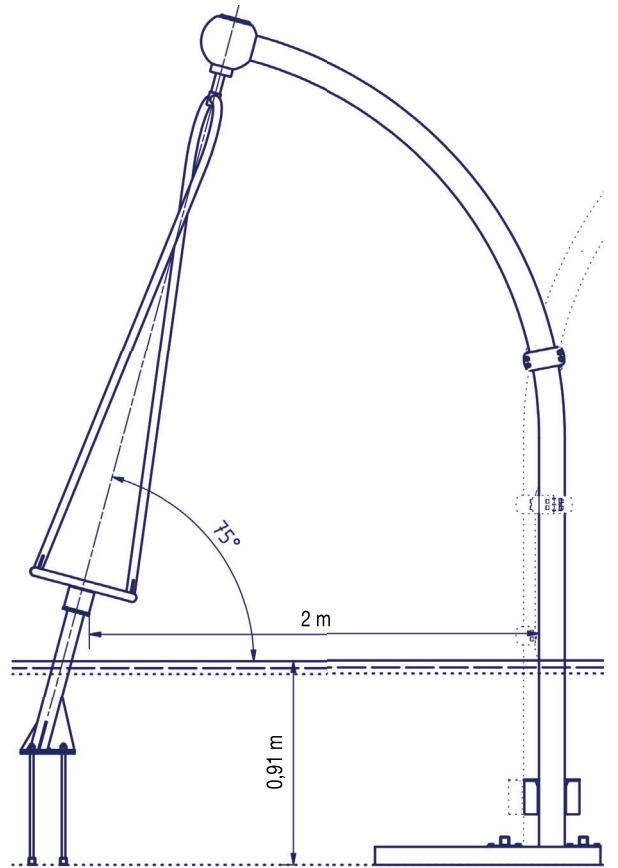
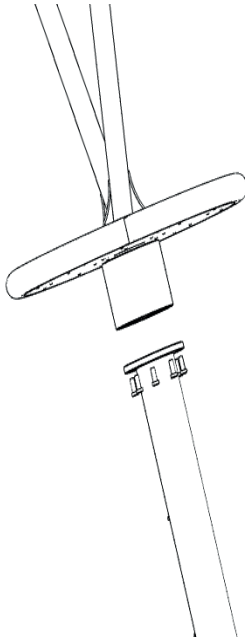
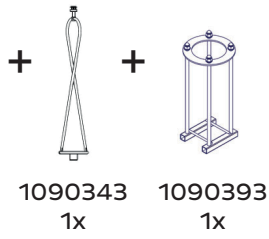

6x

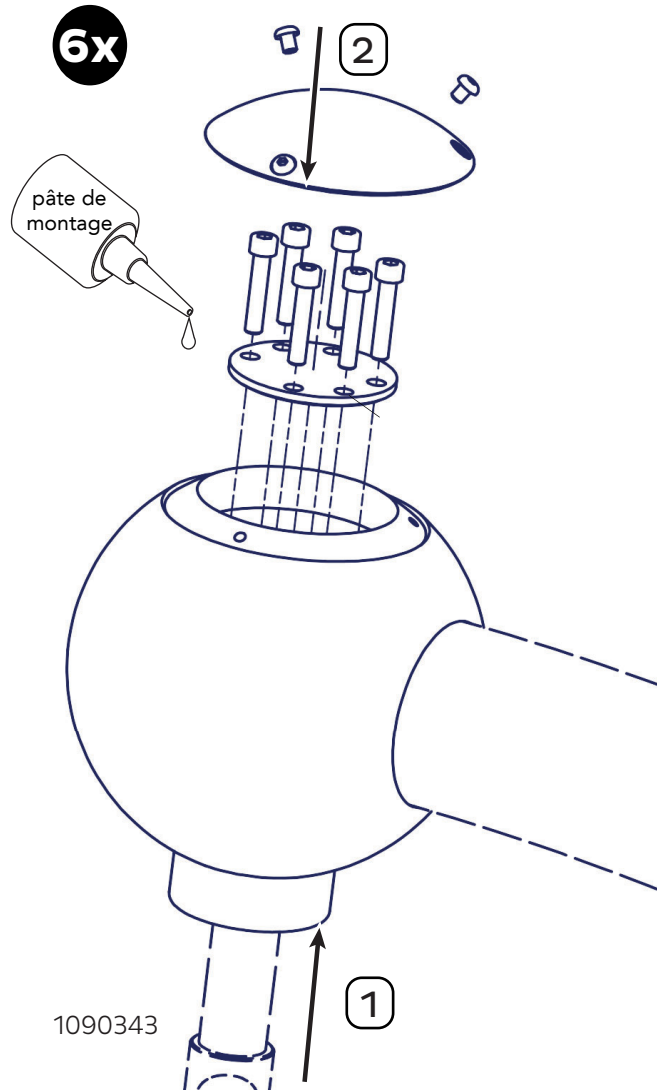



Kaiser & Kühne



Tout d'abord, installez et alignez tous les composants et serrez toutes les vis. Ensuite, préparez les fondations avec du béton comprimé C20/25 selon le plan.

Pour les jeux de cordes et les carrousels, une exception s'applique : le montage des éléments de corde et des carrousels n'a lieu qu'après la prise des fondations en béton.